

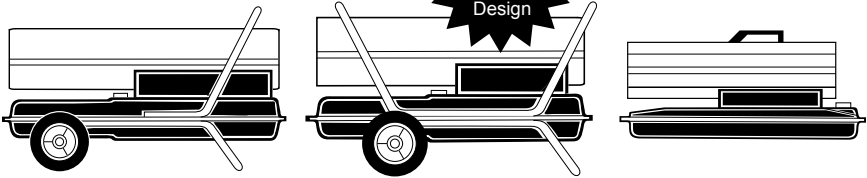

**KEROSENE/DIESEL PORTABLE FORCED AIR HEATERS
OWNER'S MANUAL**



**HEATER SIZES: 40,000, 50,000, 55,000, 60,000, 70,000, 110,000,
115,000, 155,000, 165,000 AND 200,000 BTU/HR MODELS
H.S.I. SERIES**

IMPORTANT: Read and understand this manual before assembling, starting, or servicing heater. Improper use of heater can cause serious injury. Keep this manual for future reference.

INSTALLER: Leave this manual with the appliance
CONSUMER: Retain this manual for future reference.

TABLE OF CONTENTS

Safety Information	2	Preventative Maintenance Schedule.....	7
Unpacking.....	3	Troubleshooting.....	7
Product Identification.....	3	Service Procedures	9
Fuels.....	4	Specifications	15
Theory of Operation.....	4	Wiring Diagrams.....	16
Ventilation.....	4	Illustrated Parts Breakdown and Parts List.....	18
Assembly.....	5	Replacement Parts.....	30
Operation.....	5	Technical Service.....	31
Operation With Portable Generator.....	6	Accessories.....	31
Storing, Transporting, or Shipping.....	6	Warranty and Repair Service	Back Cover

Fill In For Your Records

Model No. _____
(Located on side panel)

Serial No. _____
(Located on fuel tank)

Date of Purchase: _____



SAFETY INFORMATION

 **WARNING: This product contains and/or generates chemicals known to the State of California to cause cancer or birth defects, or other reproductive harm.**

IMPORTANT: Read this owner's manual carefully and completely before trying to assemble, operate, or service this heater. Improper use of this heater can cause serious injury or death from burns, fire, explosion, electrical shock, and carbon monoxide poisoning.

 **DANGER: Carbon monoxide poisoning may lead to death!**

Carbon Monoxide Poisoning: Early signs of carbon monoxide poisoning resemble the flu, with headaches, dizziness, and/or nausea. If you have these signs, the heater may not be working properly. **Get fresh air at once!** Have heater serviced. Some people are more affected by carbon monoxide than others. These include pregnant women, persons with heart or lung disease or anemia, those under the influence of alcohol, and those at high altitudes. Make certain you read and understand all warnings. Keep this manual for reference. It is your guide to safe and proper operation of this heater.

1. Use only kerosene, #1#2 diesel/fuel oil, JET A or JP-8 fuels to avoid risk of fire or explosion. Never use gasoline, naphtha, paint thinners, alcohol, or other highly flammable fuels.
 2. Fueling
 - a) Personnel involved with fueling shall be qualified and thoroughly familiar with the manufacturer's instructions and applicable regulations regarding the safe fueling of heating units.
 - b) Only the type of fuel specified on the heater's data plate shall be used.
 - c) All flame, including the pilot light, if any, shall be extinguished and the heater allowed to cool, prior to fueling.
 - d) During fueling, all fuel lines and fuel-line connections shall be inspected for leaks. Any leaks shall be repaired prior to returning the heater to service.
 3. Use only the electrical voltage and frequency specified on model plate.
 4. Heater must be grounded. Use only a properly grounded three-wire extension cord. Plug into grounded outlet only.
 5. Use only in areas free of flammable vapors or high dust content.
 6. Minimum clearance from any combustible materials: 8 feet (244 cm) from hot air outlet; 4 feet (122 cm) from top; and 4 feet (122 cm) from sides and inlet.
 7. Locate heater on a stable and level surface while hot or operating or a fire may occur.
 8. Use only in well-vented areas. Before using heater, provide at least a three-square-foot (2,800 square cm) opening of fresh, outside air for each 100,000 Btu/Hr (30 kw) of rating.
 9. Keep children and animals away from heater at all times.
 10. Never start heater when combustion chamber is hot or if fuel has accumulated in combustion chamber.
 11. When used with thermostat, heater may start at anytime.
 12. When heater is moved or stored, it must be in a level position or fuel spillage may occur.
 13. Use heater only in accordance with local ordinances and codes.
 14. Never use gasoline, crankcase drainings, naphtha, paint thinners, alcohol, or other highly flammable fuels.
 15. Never use heater where gasoline, paint thinner, or other highly flammable vapors are present.
 16. Never use heater in living or sleeping areas.
 17. Never leave a heater plugged in without adult supervision if children or animals are likely to be present.
- e) At no time shall more than one day's supply of heater fuel be stored inside a building in the vicinity of the heater. Bulk fuel storage shall be outside the structure.
 - f) All fuel storage shall be located a minimum of 25 feet (762 cm) from heaters, torches, welding equipment, and similar sources of ignition (exception: the fuel reservoir integral with the heater unit).
 - g) Whenever possible, fuel storage shall be confined to areas where floor penetrations do not permit fuel to drip onto or be ignited by a fire at lower elevation.
 - h) Fuel storage shall be in accordance with the authority having jurisdiction.

SAFETY INFORMATION

Continued

18. Never move, handle, refuel, or service a hot, operating, or plugged-in heater.
19. Never attach duct work to front or rear of heater.
20. Never attach heater to external fuel tank.
21. Heaters used in the vicinity of tarpaulins, canvas, or similar enclosure materials shall be located a safe distance from such materials. The recommended minimum safe distance is 10 feet (304.8 cm). It is further recommended that these enclosure materials be of a fire retardant nature. These enclosure materials shall be securely fastened to prevent them from igniting or from upsetting the heater due to wind action.
22. Unplug heater when not in use.
23. Never block air inlet (rear) or air outlet (front) of heater.
24. **Warning to New York City Residents**

For Use Only At Construction Sites in accordance with applicable NYC codes under NYC FD certificate of approval #4803, #4899, #4908, #4909, or #4934.

UNPACKING

1. Remove all packing items applied to heater for shipment.
2. Remove all items from carton.
3. Check items for any shipping damage. If heater is damaged, promptly inform dealer where you bought heater.

PRODUCT IDENTIFICATION

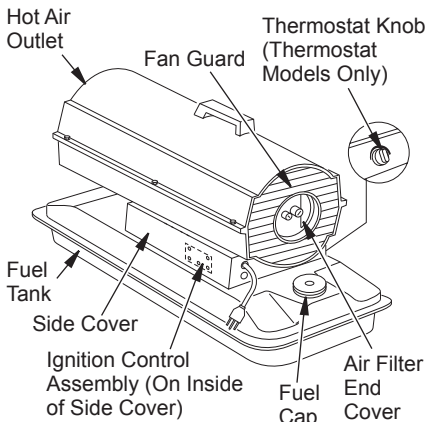

Figure 1 - 40 Models

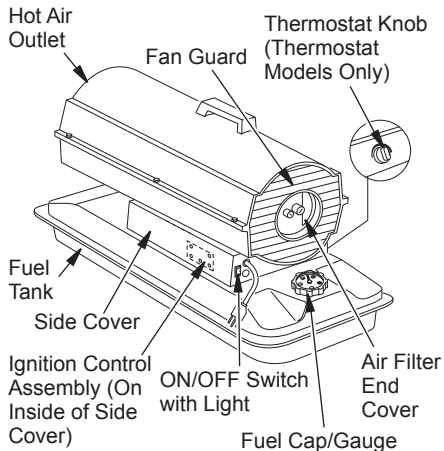

Figure 2 - 50/55/60/70 Models

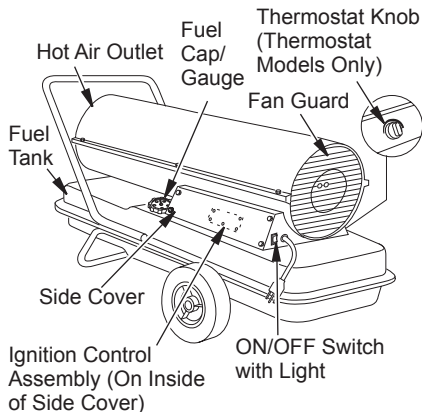

Figure 3 - 110/115/155/165 Models

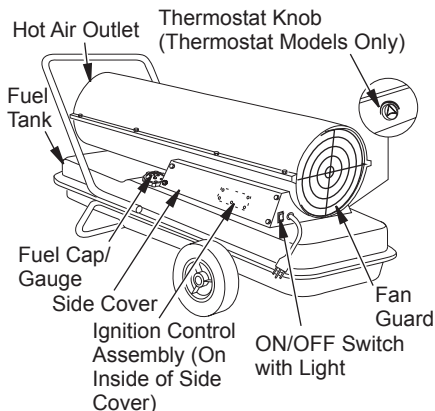

Figure 4 - 200 Model

FUELS

⚠ WARNING: Use only kerosene, #1/#2 diesel/fuel oil, JET A or JP-8 fuels to avoid risk of fire or explosion. Never use gasoline, oil drained from crankcases, naphtha, paint thinners, alcohol or other highly flammable fuels.

Use only kerosene, #1/#2 diesel/fuel oil, JET A or JP-8 fuels. Heavier fuels such as No. 2 fuel oil or No. 2 diesel fuel may also be used but will result in:

- noticeable odor
- additional fuel filter maintenance
- the need for nontoxic, anti-icer additives in very cold weather

Do not use fuels heavier than No. 2 grade or heavy oils such as oil drained from crankcases. These heavy oils will not ignite properly and will contaminate the heater.

IMPORTANT: Use a KEROSENE ONLY (blue) or DIESEL ONLY (yellow) storage container. Be sure storage container is clean. Foreign matter such as rust, dirt, or water will cause the ignition control assembly to shut down heater. Foreign matter may also require heater's fuel system to be frequently cleaned.

THEORY OF OPERATION

The Fuel System: The air pump forces air through the air line. The air is then pushed through the nozzle. This air causes fuel to be lifted from the tank. A fine mist of fuel is sprayed into the combustion chamber.

The Air System: The motor turns the fan. The fan pushes air into and around the combustion chamber. This air is heated and provides a stream of clean, hot air.

The Ignition System: The ignition control assembly provides power to the ignitor. This ignites the fuel/air mixture in the combustion chamber.

The Flame-Out Control System: This system causes the heater to shut down if the flame goes out.

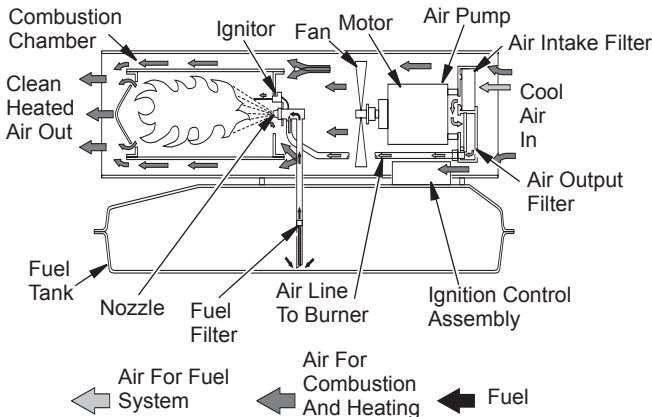

Figure 5 - Cross Section Operational View

VENTILATION

⚠ WARNING: Provide a fresh air opening of at least three square feet (2,800 square cm) for each 100,000 Btu/hr rating. Provide extra fresh air if more heaters are being used. The minimum ventilation requirements must be followed to avoid risks associated with carbon monoxide poisoning. Make certain these requirements are met prior to operating heater.

Example: A 200,000 Btu/Hr (58.6 kw) heater requires one of the following:

- a two-car garage door [16 feet (4.88 meter) opening] raised 5" (12.7 cm)
- a single-car garage door [9 feet (2.74 meter) opening] raised 8" (20.3 cm)
- two, 30" (76.2 cm) windows raised 15" (38.1 cm)

ASSEMBLY

(FOR 110/115/155/165/200 MODELS ONLY)

These models are furnished with wheels and a handle. Some models are furnished with a second handle also. Wheels, handle(s), and the mounting hardware are found in the shipping carton.

Tools Needed

- Medium Phillips Screwdriver
- 3/8" Open or Adjustable Wrench
- Hammer

1. Slide axle through wheel support frame. Install wheel spacers if provided. Install wheels on axle.

IMPORTANT: When installing wheels, point extended hub of wheels toward wheel support frame (see Figure 6).

2. Place cap nuts on axle ends. Gently tap with hammer to secure.
3. Place heater on wheel support frame. Line up holes on fuel tank flange with holes on wheel support frame.
4. Place handle(s) on top of fuel tank flange. Insert screws through handle(s), fuel tank flange, and wheel support frame. Attach nut finger tight after each screw is inserted.
5. After all screws are inserted, tighten nuts firmly.

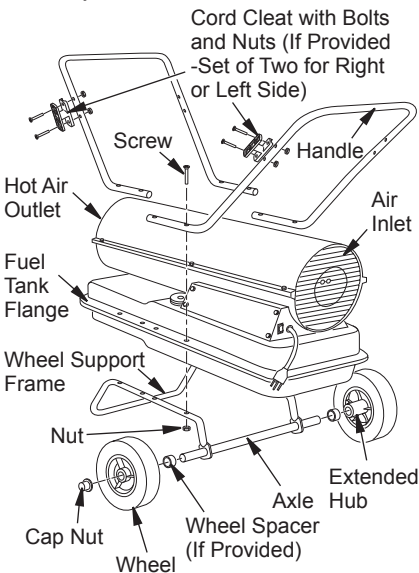

Figure 6 - Wheel and Handle Assembly, 110/115/155/165/200 Models Only

OPERATION

IMPORTANT: Review and understand the warnings in the *Safety Information* section, page 2. They are needed to safely operate this heater. Follow all local ordinances and codes when using this heater.

TO START HEATER

1. Follow all ventilation and safety information.
2. Locate heater to provide maximum circulation of the heated air. Follow all location requirements noted in *Safety Information*, page 2.
3. Fill fuel tank with kerosene, #1#2 diesel/fuel oil, JET A or JP-8 fuel.
4. Attach fuel cap.
5. For thermostat models, turn thermostat knob clockwise to the high position.
6. Plug heater's power cord into approved, grounded, three-wire extension cord. Extension cord must be at least six feet (1.8 meters) long.

Extension Cord Size Requirement

6 to 10 feet (1.8 to 3 meters) long, use 18 AWG (0.75 mm²) rated cord
11 to 100 feet (3.3 to 30.5 meters) long, use 16 AWG (1.0 mm²) rated cord
101 to 200 feet (30.8 to 61 meters) long, use 14 AWG (1.5 mm²) rated cord

7. Plug extension cord into standard 120 volt/60 hertz, 3-prong grounded outlet.

Note: For heater without ON/OFF switch, ignitor will preheat for five seconds, then heater will start.

Note: For heater with ON/OFF switch, push switch to ON(I) position and heater should start in 5 seconds. If heater does not start, see *Troubleshooting*, page 7.

8. For thermostat models, adjust thermostat knob to the desired setting. **Note:** A cold heater may affect the thermostat setting. This thermostat is a general-heating control. It is not intended for precise temperature control. Adjust thermostat until heater cycles at the desired setting.

TO STOP HEATER

Without ON/OFF Switch

Unplug extension cord from outlet.

With ON/OFF Switch

Push ON/OFF switch to OFF (O) position. Unplug heater when not in use.

OPERATION

Continued

TO RESTART HEATER

Without ON/OFF Switch

1. Unplug extension cord from outlet and wait 10 seconds. (Wait two minutes if heater has been running.)
2. Repeat steps under *To Start Heater*, page 5.

With ON/OFF Switch

1. Push ON/OFF switch to OFF (O) position and wait 10 seconds (2 minutes if heater has been running).
2. Repeat steps under *To Start Heater*, page 5.

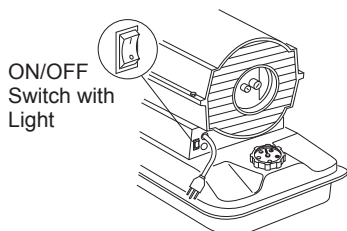

Figure 7 - ON/OFF Switch, 50/55/60/70 Models

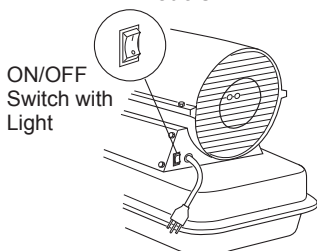

Figure 8 - ON/OFF Switch, 110/115/155/165/200 Models

OPERATION WITH PORTABLE GENERATOR

⚠ WARNING: Before operating heater or any appliance from a portable generator, verify that generator has been properly connected to earth ground. Improper grounding or failure to ground generator can result in electrocution if a ground fault occurs. Refer to owner's manual supplied by generator manufacturer for proper grounding procedures.

The operating voltage range of the heater is 108 to 132 Volts (120 Volts +/- 10%). Prior to plugging heater into generator the output voltage should be verified (if generator is equipped with the automatic idle feature, the output voltage should be measured with the generator running at full speed). If the voltage does not measure in this range the heater should not be plugged into the generator. Refer to *Operation*, page 5, for starting, stopping, and resetting heater procedures.

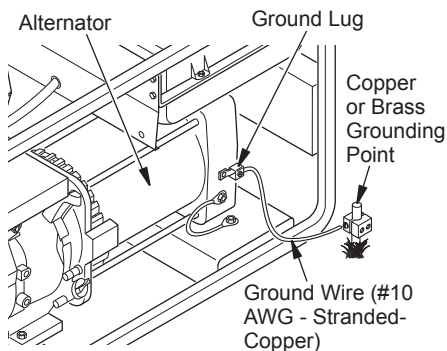

Figure 9 - Typical Generator Grounding Method (Generator construction may vary from that shown)

STORING, TRANSPORTING, OR SHIPPING

Note: If shipping, transport companies require fuel tanks to be empty.

1. Drain fuel tank. **Note:** Some models have drain plug on underside of fuel tank. If so, remove drain plug to drain all fuel. If heater does not have drain plug, drain fuel through fuel cap opening. Be sure all fuel is removed.
2. Replace drain plug if provided.
3. If any debris is noted in old fuel, add 1 or 2 quarts of clean kerosene to tank, stir, and drain again. This will prevent excess debris from clogging filters during future use.
4. Replace fuel cap or drain plug. Properly dispose of old and dirty fuel. Check with local automotive service stations that recycle oil.
5. If storing, store heater in dry place. Make sure storage place is free of dust and corrosive fumes.

IMPORTANT: Do not store kerosene over summer months for use during next heating season. Using old fuel could damage heater.

PREVENTATIVE MAINTENANCE SCHEDULE

⚠ WARNING: Never service heater while it is plugged in, operating, or hot. Severe burns and electrical shock can occur.

Item	How Often	How To
Fuel tank	Flush every 150-200 hours of operation or as needed	See <i>Storing, Transporting, or Shipping</i> , page 6
Air output and lint filters	Replace every 500 hours of operation or once a year	See <i>Air Output, Air Intake, and Lint Filters</i> , page 9
Air intake filter	Wash and dry with soap and water every 500 hours of operation or as needed	See <i>Air Output, Air Intake, and Lint Filters</i> , page 9
Fuel filter	Clean twice a heating season or as needed	See <i>Fuel Filter</i> , page 10
Ignitor	No maintenance required	
Fan blades	Clean every season or as needed	See <i>Fan</i> , page 9
Motor	Not required/permanently lubricated	

TROUBLESHOOTING

⚠ WARNING: Never service heater while it is plugged in, operating, or hot. Severe burns and electrical shock can occur.

FAULT CONDITION	POSSIBLE CAUSE	REMEDY
Motor does not start five seconds after heater is plugged in	1. No power to heater	1. Check circuit breaker in electrical panel
	2. ON/OFF switch not in the ON(I) position	2. Verify the ON/OFF switch is in ON (I) position and light is on
	3. If equipped, thermostat setting is too low	3. Turn thermostat knob to a higher setting
	⚠ WARNING: High voltage!	
	4. Bad electrical connection between motor and ignition control assembly or ignition control assembly and power cord	4. Check all electrical connections. See <i>Wiring Diagrams</i> , page 16
	5. Binding pump rotor	5. If fan does not turn freely, see <i>Pump Rotor</i> , page 14
	6. Defective ignition control assembly	6. Replace ignition control assembly
	7. Defective motor	7. Replace motor
8. Blown fuse or ignitor control assembly	8. See <i>Ignition Control Assembly</i> , page 15	

TROUBLESHOOTING

Continued

FAULT CONDITION	POSSIBLE CAUSE	REMEDY
Motor starts and runs but heater does not ignite	1. No fuel in tank	1. Fill tank with kerosene
	2. Pump pressure incorrect	2. See <i>Pump Pressure Adjustment</i> , page 10
	3. Dirty fuel filter	3. See <i>Fuel Filter</i> , page 10
	4. Obstruction in nozzle	4. See <i>Nozzle Assembly</i> , page 13
	5. Water in fuel tank	5. Drain and flush fuel tank with clean kerosene. See <i>Storing, Transporting, or Shipping</i> , page 6
<div style="border: 1px solid black; padding: 5px; display: inline-block;"> WARNING: High voltage!</div>		
	6. Bad electrical connection between ignitor and ignition control assembly	6. Check electrical connections. See <i>Wiring Diagrams</i> , page 16
	7. Defective ignitor	7. Replace ignitor, see page 11
	8. Defective ignition control assembly	8. Replace ignition control assembly

Heater ignites but ignition control assembly shuts heater off after a short period of time	1. Pump pressure incorrect	1. See <i>Pump Pressure Adjustment</i> , page 10
	2. Dirty air intake, air output, and/or lint filter	2. See <i>Air Output, Air Intake, and Lint Filters</i> , page 9
	3. Dirty fuel filter	3. See <i>Fuel Filter</i> , page 10
	4. Obstruction in nozzle	4. See <i>Nozzle Assembly</i> , page 13
	5. Photocell assembly not properly installed (not seeing the flame)	5. Make sure photocell boot is properly seated in bracket
	6. Dirty photocell lens	6. Clean photocell lens
<div style="border: 1px solid black; padding: 5px; display: inline-block;"> WARNING: High voltage!</div>		
	7. Bad electrical connection between photocell and ignition control assembly	7. Check electrical connections. See <i>Wiring Diagrams</i> , page 16
	8. Defective photocell	8. Replace photocell
	9. Defective ignition control assembly	9. Replace ignition control assembly

SERVICE PROCEDURES

WARNING: To avoid risk of burn and electrical shock, never attempt to service heater while it is plugged in, operating, or hot.

UPPER SHELL REMOVAL

1. Remove screws along each side of heater using 5/16" nut-driver. These screws attach upper and lower shells together. See Figure 10 or 11.
2. Lift upper shell off.
3. Remove fan guard.

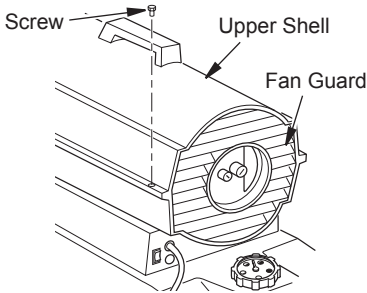

Figure 10 - Upper Shell Removal, 40/50/55/60/70 Models Only

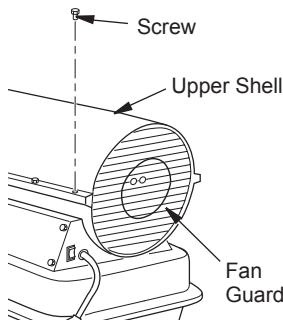

Figure 11 - Upper Shell Removal, 110/115/155/165/200 Models Only

FAN

IMPORTANT: Remove fan from motor shaft before removing motor from heater. The weight of the motor resting on the fan could damage the fan pitch (see Figure 12).

1. Remove upper shell (see Figure 10 or 11).
2. Use 1/8" allen wrench to loosen setscrew which holds fan to motor shaft.
3. Slip fan off motor shaft.

4. Clean fan using a soft cloth moistened with kerosene or solvent.
5. Dry fan thoroughly.
6. Replace fan on motor shaft. Place fan hub flush with end of motor shaft (see Figure 13).
7. Place setscrew on flat of shaft. Tighten setscrew firmly (40-50 inch-pounds/4.5-5.6 n-m).
8. Replace fan guard and upper shell.

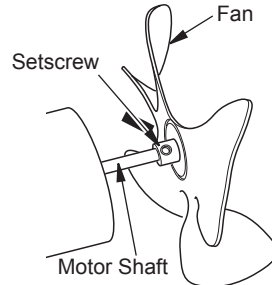

Figure 12 - Fan, Motor Shaft, and Setscrew Location

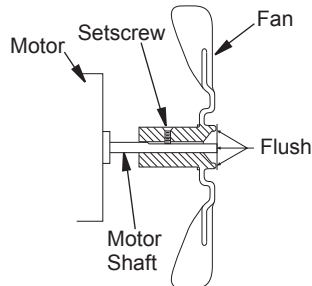

Figure 13 - Fan Cross Section

AIR OUTPUT, AIR INTAKE AND LINT FILTERS

1. Remove upper shell (see Figure 10 or 11).
2. Remove filter end cover screws using 5/16" nut-driver (see Figure 14 or Figure 15, page 10).
3. Remove filter end cover.
4. Replace air output and lint filters.
5. Wash or replace air intake filter (see *Preventative Maintenance Schedule*, page 7).

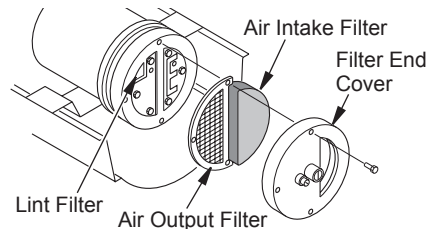

Figure 14 - Air Output, Air Intake, and Lint Filters, 40/50/55/60/70 Models Only

SERVICE PROCEDURES

Continued

- Replace filter end cover.
- Replace fan guard and upper shell.

IMPORTANT: Do not oil filters.

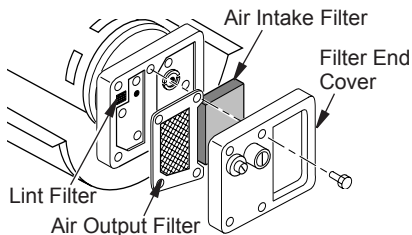

Figure 15 - Air Output, Air Intake, and Lint Filters, 110/115/155/165/200 Models Only

PUMP PRESSURE ADJUSTMENT

- Remove pressure gauge plug from filter end cover (see Figure 16).
- Install accessory pressure gauge (part number HA1180).
- Start heater (see *Operation*, page 5). Allow motor to reach full speed.
- Adjust pressure. Turn relief valve to right to increase pressure. Turn relief valve to left to decrease pressure. See specifications correct pressure for each model (see Figure 17).
- Remove pressure gauge. Replace pressure gauge plug in filter end cover.

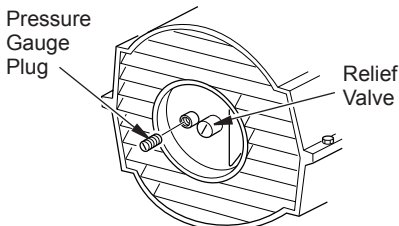

Figure 16 - Pressure Gauge Plug Removal (40/55/60/70 Models Shown)

Model	Pump Pressure
40	3.0 PSI
50	3.4 PSI
55	3.4 PSI
60	3.4 PSI
70	4.7 PSI
110	5.1 PSI
115	5.1 PSI
155	5.2 PSI
165	5.6 PSI
200	6.2 PSI

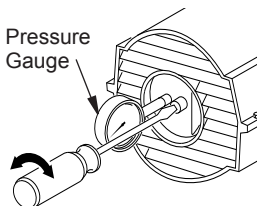

Figure 17 - Adjusting Pump Pressure (40/50/55/60/70 Models Shown)

FUEL FILTER

- Remove side cover screws using 5/16" nut-driver.
- Remove side cover.
- Pull upper fuel line off fuel filter neck (see Figure 18 or 19).
- Carefully pry bushing, fuel filter, and lower fuel line (110/115/155/165/200 Models only) out of fuel tank (see Figure 19).
- Wash fuel filter with clean fuel and replace in tank.
- Attach upper fuel line to fuel filter neck.
- Replace side cover.

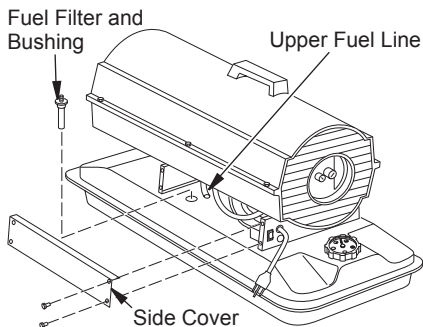

Figure 18 - Fuel Filter Removal, 40/50/55/60/70 Models

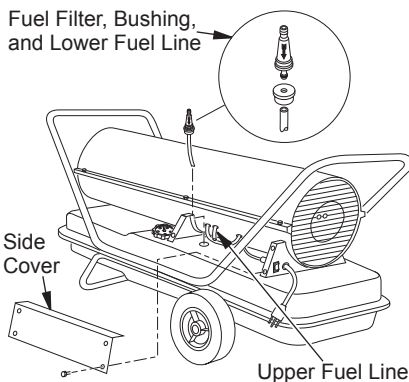

Figure 19 - Fuel Filter Removal, 110/115/155/165/200 Models

SERVICE PROCEDURES

Continued

IGNITOR

1. Remove upper shell and fan guard (See *Upper Shell Removal*, page 9).
2. Remove fan (see page 9).
3. Remove 4 side cover screws with a 5/16" nut driver. Remove side cover (see Figures 18 or 19, page 10).
4. Disconnect ignitor wires from ignition control assembly (see Figure 20). Pull the ignitor wires up through the hole in the lower shell.
5. Disconnect fuel line hose and air line hose. Remove photocell from photocell bracket (see Figure 20).
6. Remove combustion chamber. Stand combustion chamber on end with nozzle adapter bracket on top (see Figure 21 or 22).
7. Remove ignitor screw with a 1/4" nut driver for models using ignitor HA1000 or 5/16" nut driver for models using 102548-08 ignitor. Carefully remove ignitor from nozzle adapter bracket.

CAUTION: Do not bend or strike ignitor element. Handle with care.

8. Carefully remove replacement ignitor from packing.
9. Carefully guide ignitor into opening in nozzle adapter bracket. Do not strike ignitor element. Attach ignitor to nozzle adapter bracket with screw using a 1/4" nut driver for models using ignitor HA1000 or 1/16" nut driver for models using 102548-08 ignitor (see Figure 23). Torque 0.90 to 1.69 N-m (8 to 15 in-lbs) Do not over torque.
10. Replace combustion chamber.
11. Route the ignitor wires back down through the hole in the lower shell. Connect wires to the ignition control assembly (see Figure 20).
12. Replace side cover (see Figures 18 or 19, page 10).
13. Connect and route fuel line hose and air line hose to nozzle adapter assembly. See *Fuel and Air Line Replacement and Proper Routing*, page 13.
14. Replace photocell in photocell bracket. Route wires as shown in either (see Figures 23 or 24 page 12 or Figure 27, page 13).
15. Replace fan (see page 9).
16. Replace fan guard and upper shell (see page 9).

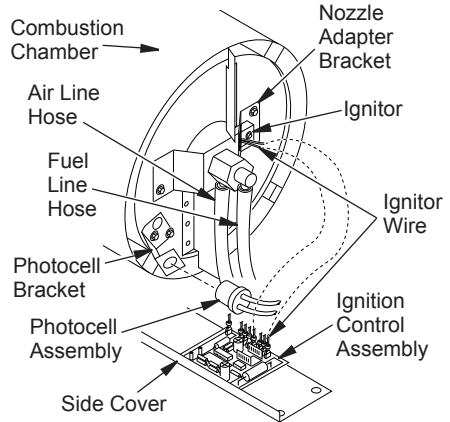

Figure 20 - Disconnecting Ignitor Wires from Ignition Control Assembly

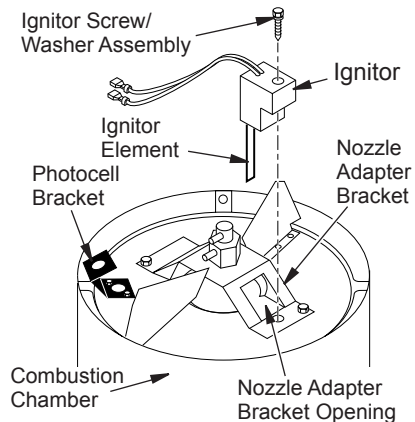

Figure 21 - Ignitor HA1000 Replacement

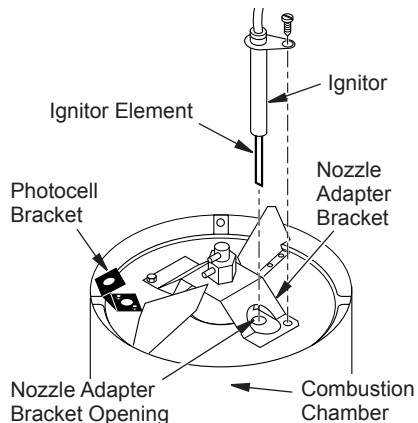

Figure 22 - Ignitor 102548-08 Replacement

SERVICE PROCEDURES

Continued

NOZZLE ASSEMBLY

(For 40/50/55/60/70/110/115/155/165 Models Only)

1. Remove upper shell (see *Upper Shell Removal*, page 9).
2. Remove fan (see *Fan*, page 9).
3. Remove fuel and air line hoses from nozzle assembly (see Figure 23 or 24).
4. Turn nozzle assembly 1/4 turn to left and pull toward motor to remove (see Figure 25).

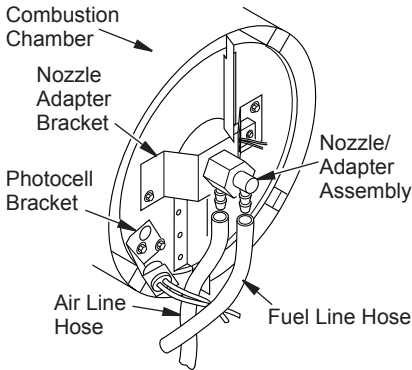

Figure 23 - Removing Air and Fuel Line Hoses (40/50/55/60/70 Models Only)

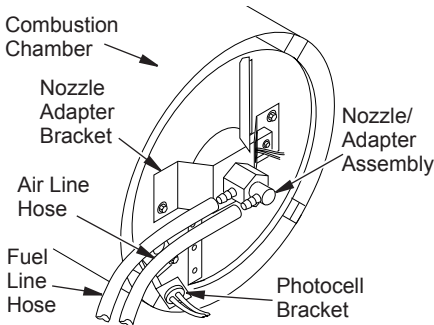

Figure 24 - Removing Air and Fuel Line Hoses (110/115/155/165 Models Only)

5. Place plastic hex-body into vise and lightly tighten.
6. Carefully remove nozzle from the nozzle adapter using 5/8" socket wrench (see Figure 26).
7. Blow compressed air through face of nozzle. This will free any dirt in nozzle area.
8. Inspect nozzle sleeve for damage.
9. Replace nozzle into nozzle adapter until nozzle seats. Tighten 1/3 turn more using 5/8" socket wrench 4.5 to 5.1 N-m (40 to 45 in-lbs). See Figure 26.
10. Attach nozzle assembly to burner strap (see Figure 25).
11. Attach fuel and airline hoses to nozzle assembly. See *Fuel and Airline Replacement and Proper Routing*, page 13.
12. Replace fan (see *Fan*, page 9).
13. Replace fan guard and upper shell (see *Upper Shell Removal*, page 9).

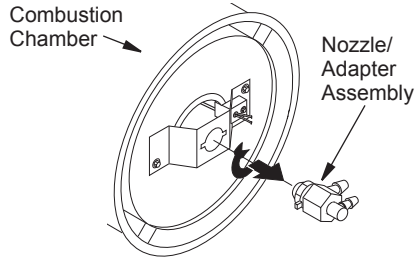

Figure 25 - Removing Nozzle/Adapter Assembly

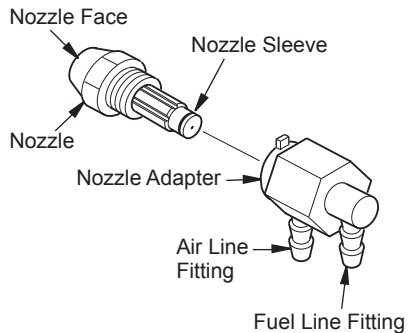

Figure 26 - Nozzle and Nozzle Adapter

SERVICE PROCEDURES

Continued

(For 200 Model Only)

1. Remove combustion chamber and ignitor by following steps 1 through 7 under *Ignitor*, page 11.
2. Carefully place the ignitor in a safe location.
3. Remove two nozzle adapter bracket screws (see Figure 27).
4. Place hex-shaped aluminum nozzle adapter into vise (do not overtighten).
5. Carefully remove nozzle from nozzle adapter using 5/8" socket wrench (see Figure 28).
6. Blow compressed air through face of nozzle. This will remove any debris in nozzle.
7. Inspect nozzle seal for damage.
8. Replace nozzle into nozzle adapter until nozzle seats. Tighten 80-110 inch-pounds.
9. Attach nozzle adapter bracket to combustion chamber with two screws removed in step 3.
10. Repeat steps 9 through 16 under *Ignitor*, page 11.

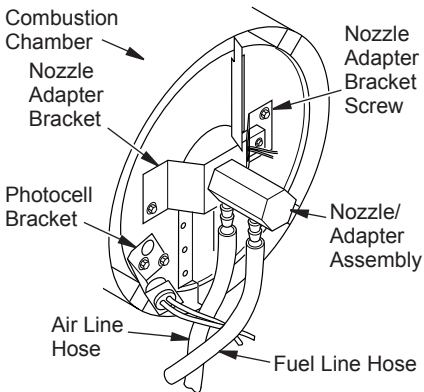

Figure 27 - Removing Air and Fuel Line Hoses (200 Model Only)

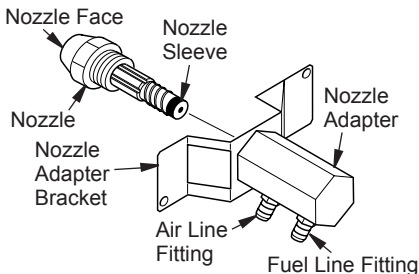

Figure 28 - Nozzle and Nozzle Adapter

FUEL AND AIR LINE REPLACEMENT AND PROPER ROUTING

1. Remove upper shell (see *Upper Shell Removal*, page 9).
2. Remove side cover screws using 5/16" nut driver (see Figure 18 or 19, page 10).
3. Remove side cover.
4. Inspect fuel and air line hoses for cracks and/or holes. If fuel line hose is damaged, disconnect from nozzle adapter (see Figure 23 or 24, page 12, or Figure 27) and from fuel filter (see *Fuel Filter*, page 10). If air line hose is damaged, disconnect from nozzle adapter (see Figure 23 or 24, page 12, or Figure 27) and from barb fitting on pump end cover (see Figure 29).
5. Install new air and/or fuel line. Attach one end of air line hose to barb fitting on pump end cover (see Figure 29) and the other end to nozzle adapter (see Figure 23 or 24, page 12, or Figure 27). Attach one end of fuel line hose to fuel filter (see *Fuel Filter*, page 10) and the other end to nozzle adapter (see Figure 23 or 24, page 12, or Figure 27).

Note: Route hoses as shown in see Figure 23 or 24, page 12, or Figure 27, according to model. Hoses are not to touch photocell bracket.

6. Replace side cover.
7. Replace upper shell and fan guard (see *Upper Shell Removal*, page 9).

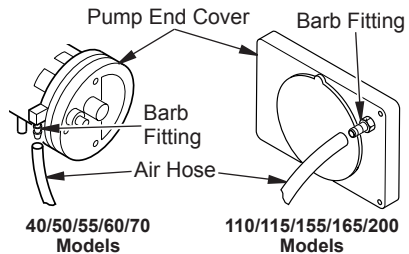

Figure 29 - Air Hose to Barb Fitting

SERVICE PROCEDURES

Continued

PUMP ROTOR

(Procedure if Rotor is Binding)

1. Remove upper shell (see *Upper Shell Removal*, page 9).
2. Remove filter end cover screws using 5/16" nut driver (see Figure 30 or 31).
3. Remove filter end cover and air filters.
4. Remove pump plate screws using 5/16" nut-driver.
5. Remove pump plate.
6. Remove rotor, insert, and blades (see Figure 30 or 31).
7. Check for debris in pump. If debris is found, blow out with compressed air.
8. Install insert and rotor.
9. Check gap on rotor. Adjust to 0.076/0.101 mm (0.003"/0.004") if needed (see Figure 32).

Note: Rotate rotor one full turn to ensure the gap is 0.076/0.101 mm (0.003"/0.004") at tightest position. Adjust if needed.

10. Install blades, pump plate, air filters, and filter end cover.
11. Replace fan guard and upper shell (see *Upper Shell Removal*, page 9).
12. Adjust pump pressure (see *Pump Pressure Adjustment*, page 10).

Note: If rotor is still binding, proceed as follows.

13. Perform steps 1 through 6.
14. Place fine grade sandpaper (600 grit) on flat surface. Sand rotor lightly in "figure 8" motion four times (see Figure 33).
15. Reinstall insert and rotor.
16. Perform steps 10 through 12.

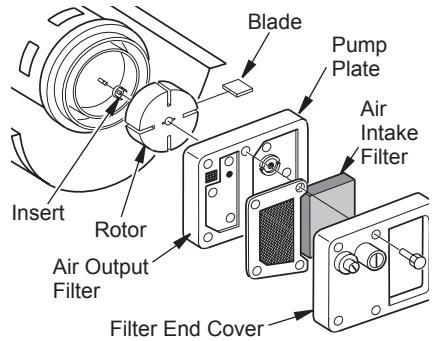

**Figure 31 - Rotor Location,
110/115/155/165/200 Models**

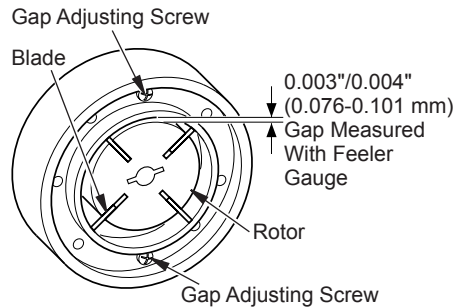

**Figure 32 - Gap Adjusting Screw
Locations**

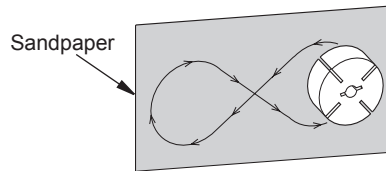
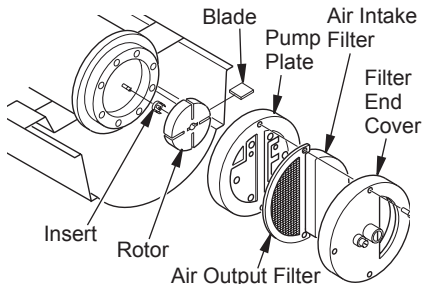

Figure 33 - Sanding Rotor



**Figure 30 - Rotor Location,
40/50/55/60/70 Models**

SERVICE PROCEDURES

Continued

IGNITION CONTROL ASSEMBLY

WARNING: High voltage!

1. Unplug heater.
2. Remove side cover screws (4) using 5/16" nut-driver to expose ignition control assembly.
3. Remove fuse cover (see Figure 34).
4. Remove fuse from fuse clips (see Figure 34).
5. Replace fuse with fuse of the same type and rating (GMA-10). Do not substitute a fuse with a higher current rating.
6. Replace fuse cover (see Figure 34).
7. Replace side cover (see Figures 18 or 19, page 10).

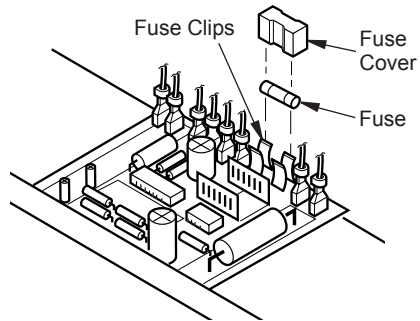

Figure 34 - Replacing Fuse

SPECIFICATIONS

All Models

- Fuel: Use only kerosene, #1/#2 diesel/fuel oil, JET A or JP-8 fuels*
- Electric Requirements: 120 V/60 HZ

40 Models

- Output Rating: 40,000 Btu/Hr
- Fuel Tank Capacity: 3 gal (11.3 ltr)
- Fuel Consumption Per Hour: 0.3 gal (1.14 ltr)
- Pump Pressure (psi): 3.0
- Amperage (Normal Run): 2.0
- Motor RPM: 1725
- Hot Air Output (CFM): 170
- Motor HP: 1/15

50/55/60 Models

- Output Rating: 50/55/60,000 Btu/Hr
- Fuel Tank Capacity: 5 gal (18.9 ltr)
- Fuel Consumption Per Hour: 0.44 gal (1.67 ltr)
- Pump Pressure (psi): 3.4
- Amperage (Normal Run): 2.0
- Motor RPM: 1725
- Hot Air Output (CFM): 180
- Motor HP: 1/15

70 Models

- Output Rating: 70,000 Btu/Hr
- Fuel Tank Capacity: 5 gal (18.9 ltr)
- Fuel Consumption Per Hour: 0.52 gal (1.97 ltr)
- Pump Pressure (psi): 4.7
- Amperage (Normal Run): 2.8
- Motor RPM: 3400
- Hot Air Output (CFM): 360
- Motor HP: 1/8

* Use of #2 diesel & fuel oil will result in noticeable odor and could require additional fuel filter maintenance. Use in extreme cold temperatures may require nontoxic anti-icer additives.

110/115 Models

- Output Rating: 110/115,000 Btu/Hr
- Fuel Tank Capacity: 9 gal (34 ltr)
- Fuel Consumption Per Hour: 0.85 gal (3.0 ltr)
- Pump Pressure (psi): 5.1
- Amperage (Normal Run): 3.6
- Motor RPM: 3400
- Hot Air Output (CFM): 490
- Motor HP: 1/5

155 Models

- Output Rating: 155,000 Btu/Hr
- Fuel Tank Capacity: 13.5 gal (51 ltr)
- Fuel Consumption Per Hour: 1.14 gal (4.31 ltr)
- Pump Pressure (psi): 5.2
- Amperage (Normal Run): 3.6
- Motor RPM: 3400
- Hot Air Output (CFM): 550
- Motor HP: 1/5

165 Models

- Output Rating: 165,000 Btu/Hr
- Fuel Tank Capacity: 13.5 gal (51 ltr)
- Fuel Consumption Per Hour: 1.2 gal (4.54 ltr)
- Pump Pressure (psi): 5.6
- Amperage (Normal Run): 3.6
- Motor RPM: 3400
- Hot Air Output (CFM): 575
- Motor HP: 1/5

200 Models

- Output Rating: 200,000 Btu/Hr
- Fuel Tank Capacity: 13.5 gal (51 ltr)
- Fuel Consumption Per Hour: 1.4 gal (5.3 ltr)
- Pump Pressure (psi): 6.2
- Amperage (Normal Run): 3.6
- Motor RPM: 3400
- Hot Air Output (CFM): 600
- Motor HP: 1/4

WIRING DIAGRAMS

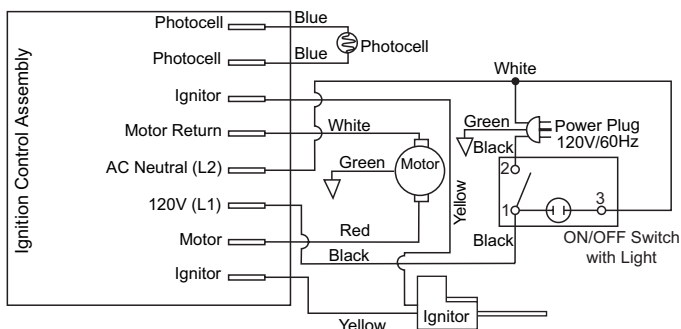
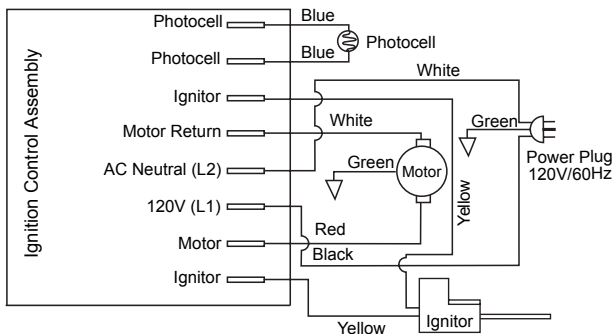

Figure 35 - Wiring Diagram without Thermostat
(40/50/55/60/70/110/115/155/165/200 Models with Ignitor HA1000)

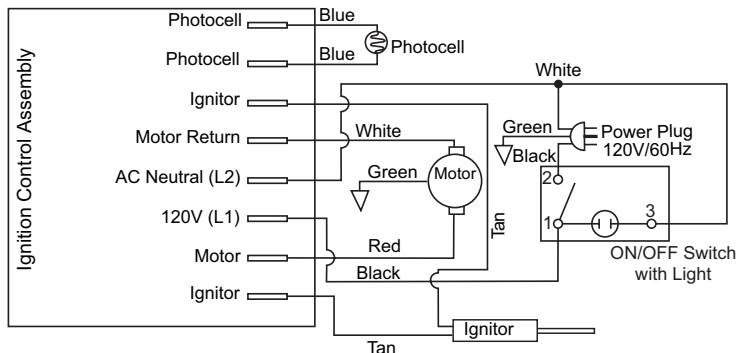
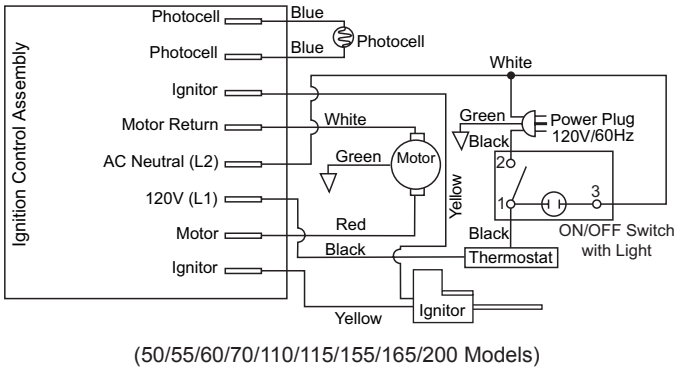
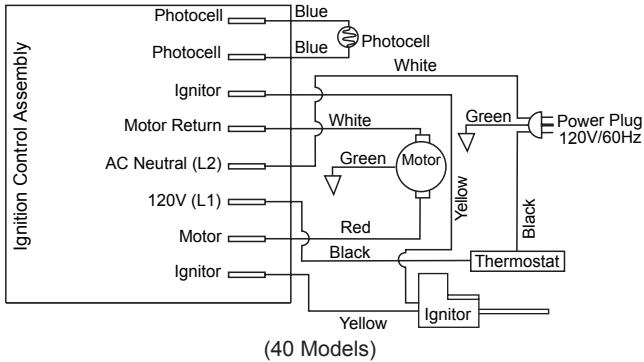

Figure 36 - Wiring Diagram without Thermostat
(50/55/60 Models with Ignitor 102548-08)

WIRING DIAGRAMS

Continued



**Figure 37 - Wiring Diagram with Thermostat
(40/50/55/60/70/110/115/155/165/200 Models with Ignitor HA1000)**

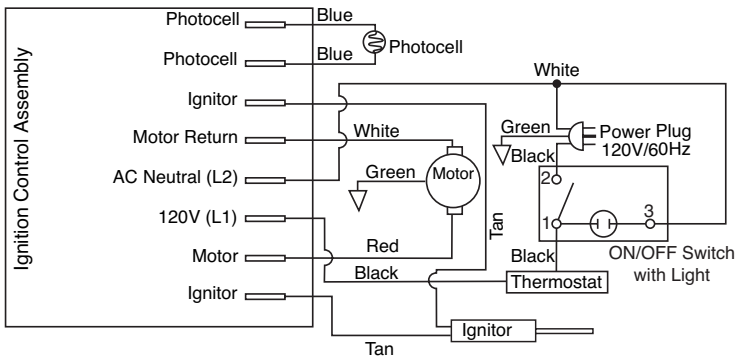
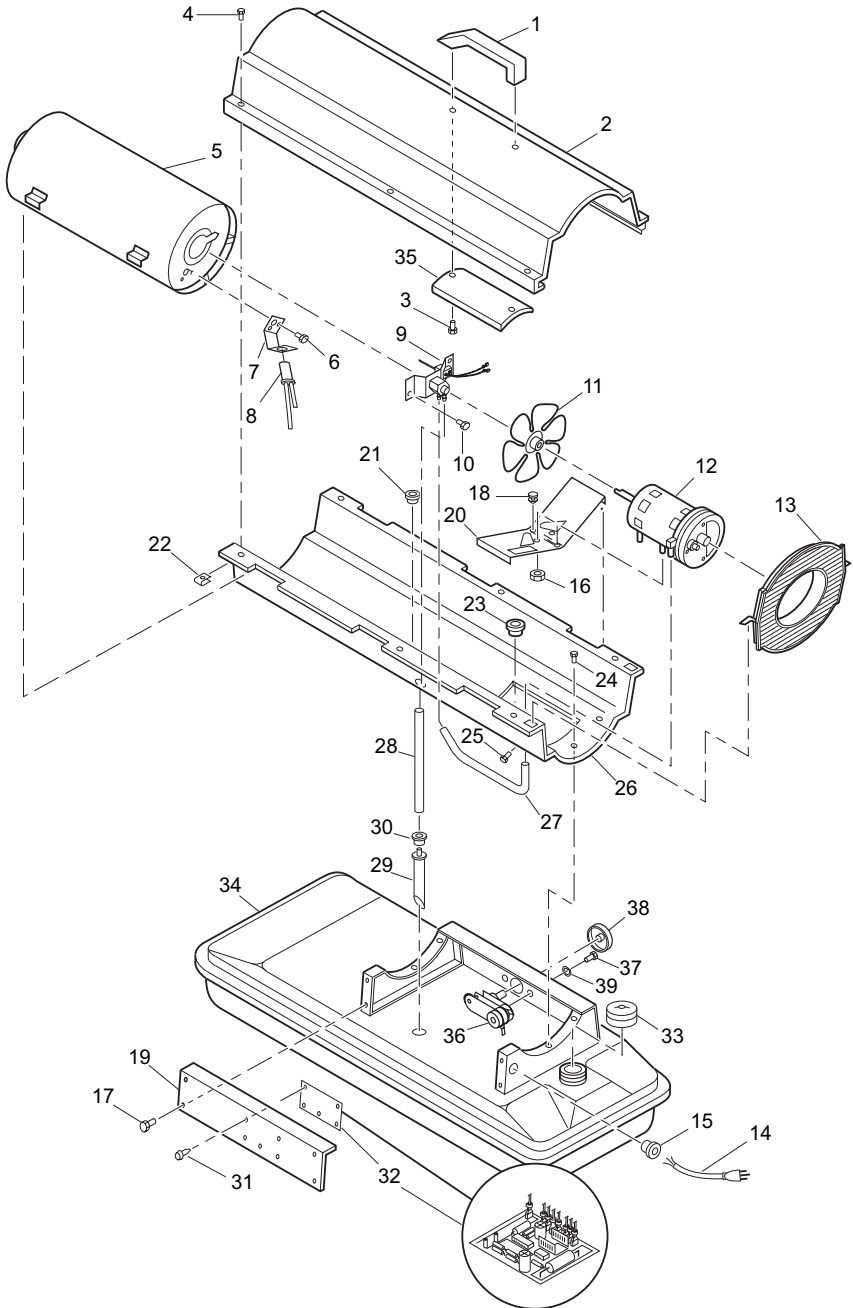

**Figure 38 - Wiring Diagram with Thermostat
(50/55/60 Models with Ignitor 102548-08)**

ILLUSTRATED PARTS BREAKDOWN

STANDARD MODELS R40 AND REM40

THERMOSTAT MODELS R40T AND N40T



PARTS LIST

40 MODELS

This list contains replaceable parts used in your heater. When ordering parts, be sure to provide the correct model and serial numbers (from the model plate), then the part number and description of the desired part.

KEY NO.	PART NO.	DESCRIPTION	QTY.
1	M51104-01	Handle	1
2	098511-67	Upper Shell (Service Part Will Be Black)	1
3	M11084-29	Screw, #10-16 x 3/4"	2
4	M15823-27	Screw, #10-16 x 1 1/2"	6
5	098512-58	Combustion Chamber	1
6	M10908-2	Screw, #6-32 x 3/8"	2
7	103154-03	Photocell Bracket	1
8	M16656-24	Photocell Assembly	1
9	(See page 26)	Burner Head Assembly	1
10	M11084-26	Screw, #10-16 x 3/8"	2
11	103684-01	Fan	1
12	(See page 27)	Motor and Pump Assembly	1
13	M51105-01	Fan Guard	1
14	098219-38	Power Cord	1
15	M11143-1	Strain Relief Bushing	1
16	NTC-4C	Hex Lock Nut, 1/4-20	2
17	M11084-26	Screw, #10-16 x 3/8"	8
18	M50631	Rubber Bumper	2
19	097461-16	Side Cover	2
20	101205-01	Motor Bracket	1
21	M50104-06	Bushing	1
22	M11271-8	Clip Nut	6
23	M50104-02	Bushing	1
24	M11084-26	Screw, #10-16 x 3/8"	6
25	M10908-14	Screw, #8-32 x 3/8"	1
26	098511-234	Lower Shell (Service Part Will Be Black)	1
27	M50814-06	Rubber Airline	1
28	079973-01	Fuel Line	1
29	M50876-04	Fuel Filter with bushing	1
30	M10990-3	Rubber Bushing	1
31	102349-01	PCB Support	5
32	104068-02	Ignition Control Assembly	1
33	097702-01	Fuel Cap (Includes Gasket)	1
34	108088-01	Fuel Tank	1
35	M51108-01	Shell Heat-Shield	1
36	104458-01	Thermostat	1
37	M12461-18	Screw, #8-32 x 7/8"	1
38	104460-01	Thermostat Knob	1
39	WLE-2	Lock Washer, EXT #8	1
PARTS AVAILABLE - NOT SHOWN			
	103814-01	Wire Tie (For Ignition Control Assembly)	1
	M9900-170	Wire Assembly (Thermostat to Ignition Control Assembly)	1

ILLUSTRATED PARTS BREAKDOWN

STANDARD MODELS R60A, PK55, UK55, REM60A AND PK60

THERMOSTAT MODELS R55CT, B55CT, R70ET, B70ET AND UK70T

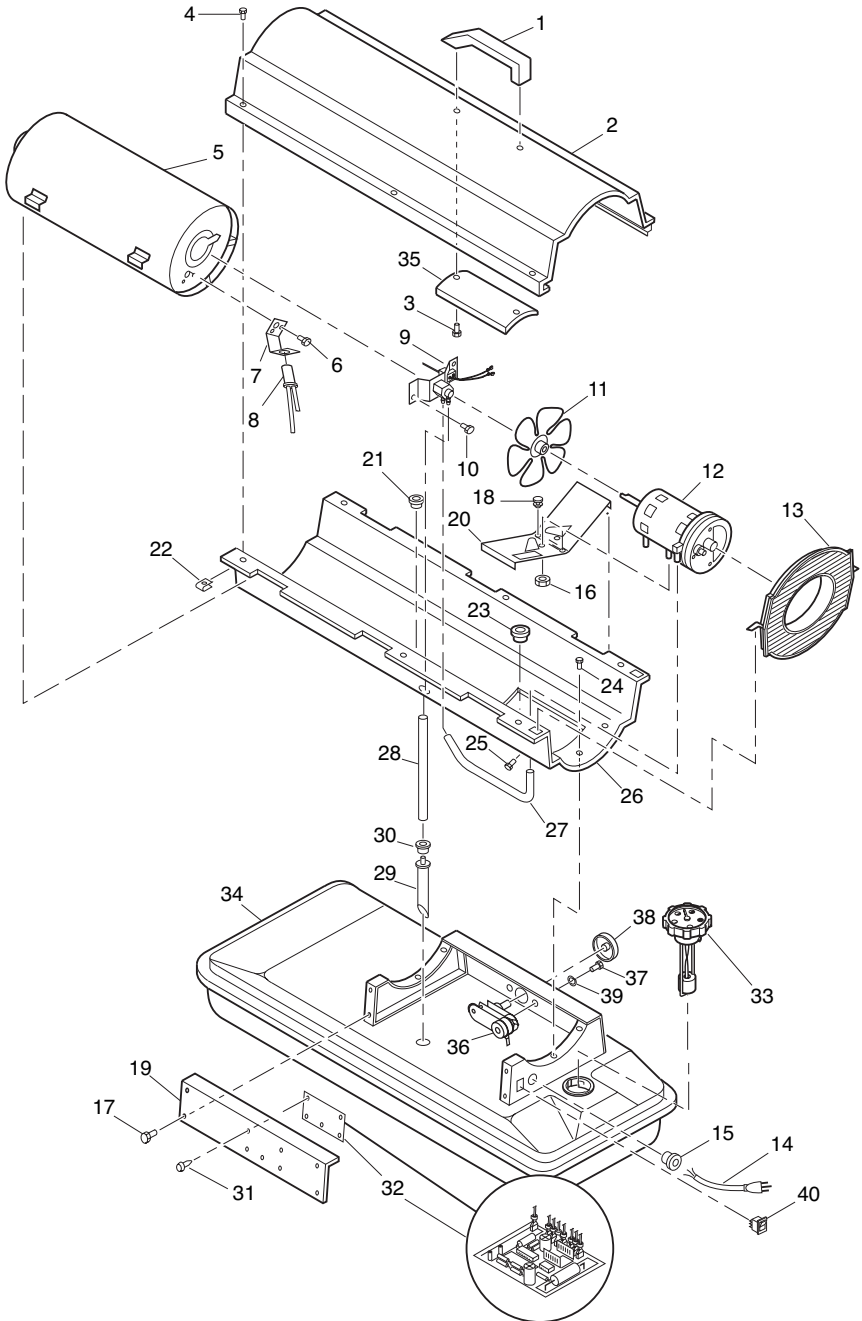

PARTS LIST

50/55/60/70 MODELS

This list contains replaceable parts used in your heater. When ordering parts, be sure to provide the correct model and serial numbers (from the model plate), then the part number and description of the desired part.

KEY

KEY NO.	PART NO.	DESCRIPTION	QTY.
1	M51104-01	Handle	1
2	098511-67	Upper Shell (Service Part Will Be Black)	1
3	M11084-29	Screw, #10-16 x 3/4"	2
4	M1582 3-27	Screw, #10-16 x 1 1/2"	6
5	098512-50	Combustion Chamber (50/55/60) for use with Ignitor HA1000	1
	098512-76	Combustion Chamber (50/55/60) for use with Ignitor 102548-08	1
	098512-51	Combustion Chamber (70)	1
6	M10908-2	Screw, #6-32 x 3/8"	2
7	103154-03	Photocell Bracket	1
8	M16656-24	Photocell Assembly	1
9	(See page 26)	Burner Head Assembly	1
10	M11084-26	Screw, #10-16 x 3/8"	2
11	103684-01	Fan (50/55/60)	1
	M29678	Fan (70)	1
12	(See page 27)	Motor and Pump Assembly	1
13	M51105-01	Fan Guard	1
14	113065-01	Power Cord	1
15	M11143-1	Strain Relief Bushing	1
16	NTC-4C	Hex Lock Nut, 1/4-20	2
17	M11084-26	Screw, #10-16 x 3/8"	8
18	M50631	Rubber Bumper	2
19	097461-16	Side Cover	2
20	101205-01	Motor Bracket	1
21	M50104-06	Bushing	1
22	M11271-8	Clip Nut	6
23	M50104-02	Bushing	1
24	M11084-26	Screw, #10-16 x 3/8"	6
25	M10908-14	Screw, #8-32 x 3/8"	1
26	098511-234	Lower Shell (Service Part Will Be Black)	1
27	M50814-06	Rubber Airline	1
28	079973-01	Fuel Line	1
29	M50876-05	Fuel Filter with bushing	1
30	M10990-3	Rubber Bushing	1
31	102349-01	PCB Support	5
32	104068-02	Ignition Control Assembly	1
33	097663-04	Fuel Cap w/ Gauge (includes Gasket) (Use with Fuel Tank 108088-16)	1
	113280-01	Fuel Cap w/ Gauge (includes Gasket) (Use with Fuel Tank 113279-01)	1
34	108088-16	Fuel Tank (Metal Filler Neck)	1
	113279-01	Fuel Tank (Plastic Filler Neck)	1
35	M51108-01	Shell Heat-Shield	1
36	104458-01	Thermostat	1
37	M12461-18	Screw, #8-32 x 7/8"	1
38	104460-01	Thermostat Knob	1
39	WLE-2	Lock Washer, EXT #8	1
40	113461-01	ON/OFF Switch	1
PARTS AVAILABLE - NOT SHOWN			
	103814-01	Wire Tie (For Ignition Control Assembly)	1
	M9900-170	Wire Assembly (Thermostat to Ignition Control Assembly)	1
	079010-46	Wire Assembly (Connects Switch to Thermostat or Ignition Control)	1

ILLUSTRATED PARTS BREAKDOWN

STANDARD MODELS PK110 AND R155D

THERMOSTAT MODELS R115DT, B115DT, REM115DT, PK115T, B155DT, R165DT, B165DT, PK165T, UK165T AND SB165DT

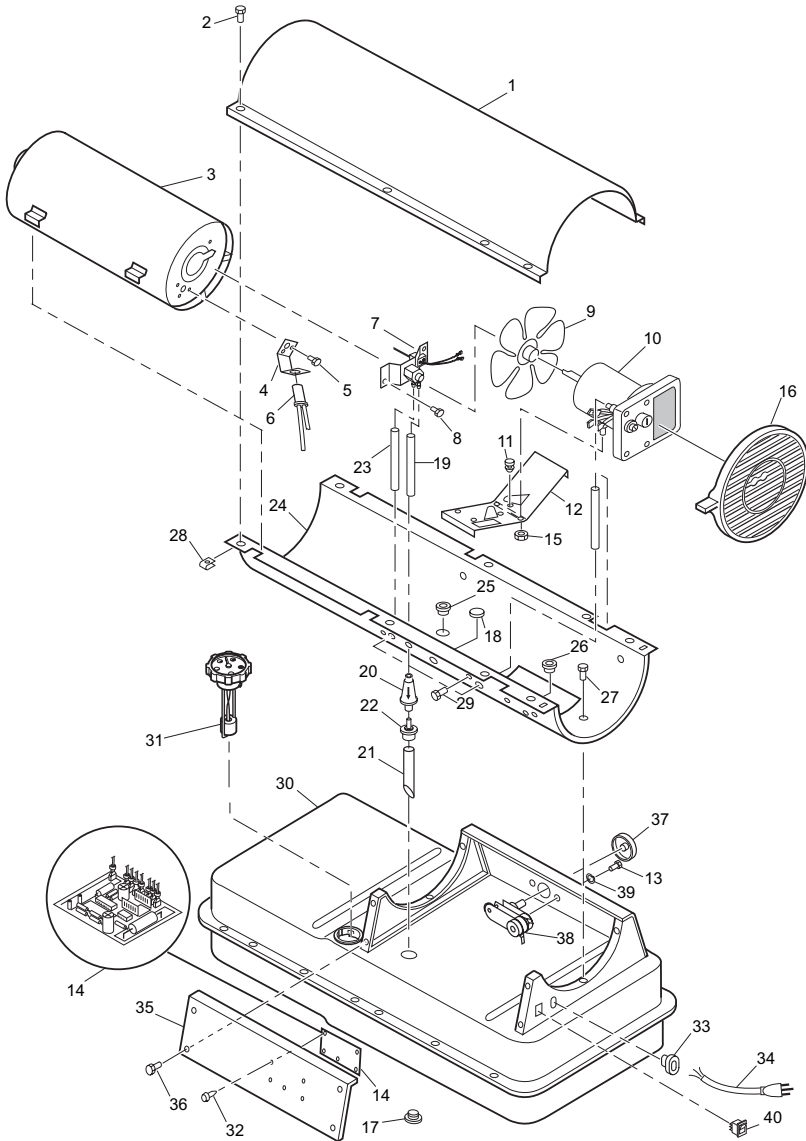

PARTS LIST

110/115/155/165 MODELS

This list contains replaceable parts used in your heater. When ordering parts, be sure to provide the correct model and serial numbers (from the model plate), then the part number and description of the desired part.

KEY

NO.	PART NO.	DESCRIPTION	QTY.
1	098511-292	Upper Shell (Service Part Will Be Black)	1
2	M15823-27	Screw, #10-16 x 1/2"	8
3	098512-71	Combustion Chamber (110/115)	1
	098512-74	Combustion Chamber (155)	1
	098512-75	Combustion Chamber (165)	1
4	103154-05	Photocell Bracket (110/115)	1
	M16660-02	Photocell Bracket (155/165)	1
5	M10908-2	Screw, #6-32 x 3/8"	2
6	M16656-24	Photocell Assembly	1
7	(See page 26)	Burner Head Assembly	1
8	M11084-26	Screw, #10-16 x 3/8"	2
9	097293-01	Fan (110/115/155)	1
	102042-01	Fan (165)	1
10	(See page 28)	Motor and Pump Assembly	1
11	M50631	Rubber Bumper	2
12	101206-01	Motor Mounting Bracket	1
13	M12461-18	Screw, #8-32 x 7/8"	1
14	104068-02	Ignition Control Assembly	1
15	NTC-4C	Hex Lock Nut, 1/4-20	2
16	111037-01	Fan Guard	1
17	M27417	Drain Plug (Includes "o" Ring)	1
18	107878-02	Button Plug	1
19	M51345-06	Fuel Line	1
20	106896-01	Fuel Filter	1
21	M51151-01	Fuel Line Tube (110/115)	1
	M51151-02	Fuel Line Tube (155/165)	1
22	M10990-3	Rubber Bushing	1
23	M50814-03	Airline	1
24	098511-293	Lower Shell (Service Part Will Be Black)	1
25	M50104-06	Bushing	1
26	M50104-01	Bushing	1
27	M11084-26	Screw, #10-16 x 3/8"	6
28	M11271-8	Clip Nut	8
29	M10908-14	Screw, #8-32 x 3/8"	1
30	108088-11	Fuel Tank (Metal Filler Neck) 110/115	1
	108088-10	Fuel Tank (Metal Filler Neck) 155/165	1
	113279-02	Fuel Tank (Plastic Filler Neck) 110/115	1
	113279-03	Fuel Tank (Plastic Filler Neck) 155/165	1
31	097663-02	Fuel Cap w/ Gauge (includes Gasket) 110/115 (Use with Fuel Tank 108088-11)	1
	097663-03	Fuel Cap w/ Gauge (includes Gasket) 155/165 (Use with Fuel Tank 108088-10)	1
	113280-02	Fuel Cap w/ Gauge (includes Gasket) 110/115 (Use with Fuel Tank 113279-02)	1
	113280-03	Fuel Cap w/ Gauge (includes Gasket) 110/115 (Use with Fuel Tank 113279-03) 155-165	1
32	102349-01	P.C. Board Support	5
33	M11143-1	Strain Relief Bushing	1
34	113065-01	Power Cord	1
35	M51077-18	Side Cover	2
36	M11084-26	Screw, #10-16 x 3/8"	8
37	104460-01	Thermostat Knob	1
38	104458-01	Thermostat	1
39	WLE-2	Lock Washer, EXT #8	1
40	113461-01	ON/OFF Switch with Light	1
	103814-01	Wire Tie (Not Shown - Groups wires connected to Ignition Control Assembly)	1
	M9900-77	Wire (Not Shown - Connects T-stat to Ignition Control Assembly)	1
	079010-46	Wire (Not Shown - Connects ON/OFF Switch to Ignition Control Assembly or Thermostat if Equipped)	1

ILLUSTRATED PARTS BREAKDOWN

THERMOSTAT MODELS B200BT AND R200BT

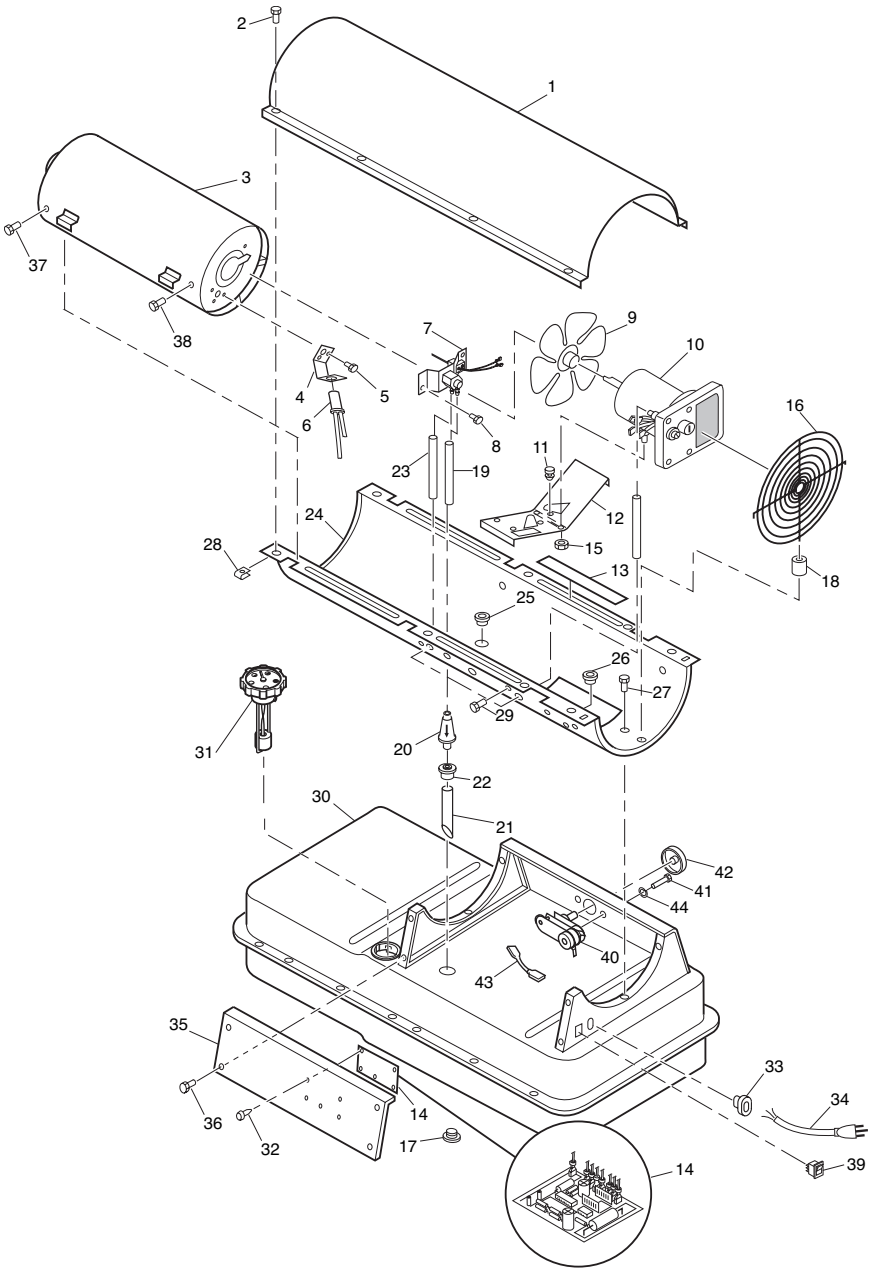

PARTS LIST

200 MODELS

This list contains replaceable parts used in your heater. When ordering parts, be sure to provide the correct model and serial numbers (from the model plate), then the part number and description of the desired part.

KEY NO.	PART NO.	DESCRIPTION	QTY.
1	107353-10	Upper Shell (Service Part Will Be Black)	1
2	M15823-27	Screw, #10-16 x 1/2"	8
3	098512-78	Combustion Chamber	1
4	M16660	Photocell Bracket	1
5	M10908-2	Screw, #6-32 x 3/8"	2
6	M16656-24	Photocell Assembly	1
7	(See page 26)	Burner Head Assembly	1
8	M11084-26	Screw, #10-16 x 3/8"	2
9	102042-01	Fan	1
10	(See page 29)	Motor and Pump Assembly	1
11	M50631	Rubber Bumper	2
12	101206-01	Motor Mounting Bracket	1
13	097785-04	Foam Gasket	2
14	104068-02	Ignition Control Assembly	1
15	NTC-4C	Hex Lock Nut, 1/4-20	2
16	102756-01	Fan Guard	1
17	M27417	Drain Plug (Includes "o" Ring)	1
18	103523-01	Rubber Bushing	1
19	M51345-04	Fuel Line	1
20	M51150-01	Fuel Filter	1
21	M51151-02	Fuel Line Tube	1
22	M10990-3	Rubber Bushing	1
23	M50814-03	Airline	1
24	107353-11	Lower Shell (Service Part Will Be Black)	1
25	M50104-06	Bushing	2
26	M50104-01	Bushing	1
27	M11084-26	Screw, #10-16 x 3/8"	6
28	M11271-8	Clip Nut	8
29	M10908-14	Screw, #8-32 x 3/8"	1
30	108088-17	Fuel Tank (Metal Filler Neck)	1
	113279-04	Fuel Tank (Plastic Filler Neck)	1
31	097663-03	Fuel Cap w/ Gauge (includes Gasket) (Use with Fuel Tank 108088-17)	1
	113280-03	Fuel Cap w/ Gauge (includes Gasket) (Use with Fuel Tank 113279-04)	1
32	102349-01	P.C. Board Support	5
33	M11143-1	Strain Relief Bushing	1
34	113065-01	Power Cord	1
35	107333-04AA	Side Cover	1
36	M11084-26	Screw, #10-16 x 3/8"	8
37	099230-01	Screw, Special	2
38	M11084-27	Screw, #10-16 x 1/2"	2
39	113461-01	ON/OFF Switch with Cover	1
40	104458-01	Thermostat	1
41	M12461-18	Screw, #8-32 x 7/8"	1
42	104460-01	Thermostat Knob	1
43	079010-35	Wire Assembly	1
44	WLE-2	Lock Washer, EXT #8	1
	103814-01	Wire Tie (Not Shown - For Ignition Control Assembly)	1
	100621-06	Thermostat Decal (Not Shown)	1
	079010-46	Wire (Not Shown - For ON/OFF Switch)	1

ILLUSTRATED PARTS BREAKDOWN

BURNER HEAD ASSEMBLY FOR 40/50/55/60/70 MODELS WITH HA1000 IGNITOR

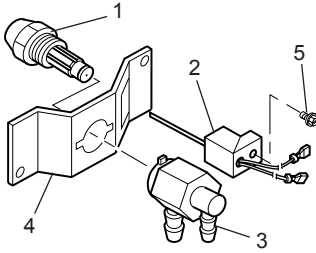

KEY

NO.	PART NO.	DESCRIPTION	QTY.
1	HA3006	Nozzle Assembly (40)	1
	HA3024	Nozzle Assembly (50/55/60)	1
	HA3026	Nozzle Assembly (70)	1
2	HA1000	Ignitor Kit	1
3	104056-01	Nozzle Adapter	1
4	102336-01	Nozzle Adapter Bracket	1
5	M10908-75	Screw, Hex Head, Tapping	1
6	103347-01	Belleville Washer	1

BURNER HEAD ASSEMBLY FOR 50/55/60 MODELS WITH 102548-08 IGNITOR

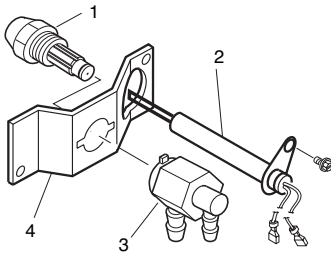

KEY

NO.	PART NO.	DESCRIPTION	QTY.
1	HA3024	Nozzle Assembly	1
2	HA1100	Ignitor Kit	1
3	102336-05	Nozzle Adapter Bracket	1
4	104056-01	Nozzle Adapter	1

BURNER HEAD ASSEMBLY FOR 110/115/155/165 MODELS

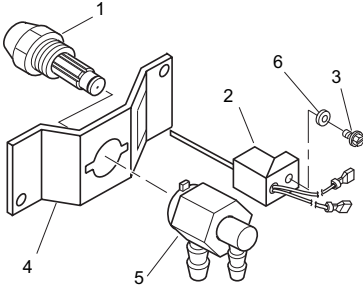

KEY

NO.	PART NO.	DESCRIPTION	QTY.
1	HA3027	Nozzle Assembly (110/115)	1
	HA3028	Nozzle Assembly (155/165)	1
2	HA1000	Ignitor Kit	1
3	M10908-75	Screw, #6-32 x 7/8"	1
4	102336-01	Nozzle Adapter Bracket	1
5	104054-01	Nozzle Adapter	1
6	103347-01	Washer	1

NOZZLE/BURNER HEAD ASSEMBLY FOR 200 MODELS

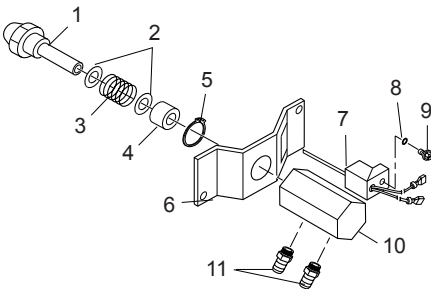

KEY

NO.	PART NO.	DESCRIPTION	QTY.
1	100735-13	Nozzle Assembly	1
2	M10659-1	Nozzle Washer	2
3	M10809-1	Nozzle Spring	1
4	M8882	Nozzle Sleeve	1
5	107272-01	Retaining Ring	1
6	102336-03	Nozzle Adapter Bracket	1
7	HA1000	Ignitor Kit	1
8	103347-01	Belleville Washer	1
9	M10908-75	Screw, #6-32 x .88	1
10	107273-01	Nozzle Adapter	1
11	M50820-02	Barb Fitting	1

ILLUSTRATED PARTS BREAKDOWN

MOTOR AND PUMP ASSEMBLY FOR 40/50/55/60/70 MODELS

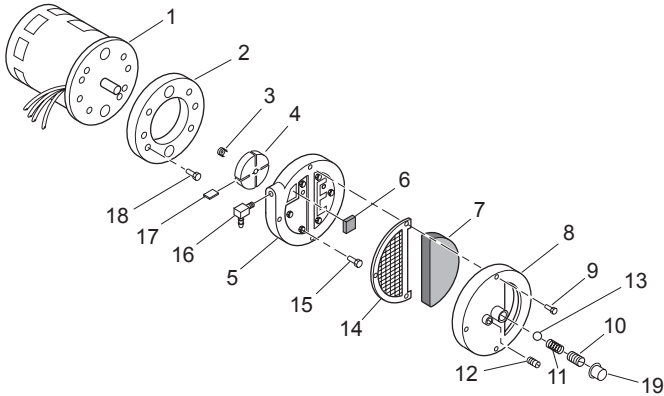

KEY

NO.	PART NO.	DESCRIPTION	QTY.
1	102001-28	Motor (40/50/55/60)	1
	102001-29	Motor (70)	1
2	079975-03	Pump Body (50/55/60)	1
	079975-02	Pump Body (40/70)	1
3	M22009**, ***	Insert	1
4	M22456-2**	Rotor (50/55/60)	1
	M22456-1***	Rotor (40/70)	1
5	M29608	Pump End Cover	1
6	M29632 ⊕	Lint Filter	1
7	M29633 ⊕	Intake Filter	1
8	M29609	Filter End Cover	1
9	M12461-31	Screw, #10-32 x 1"	3
10	M27694 ∞	Adjusting Screw	1
11	M10993-1 ∞	Pressure Relief Spring	1
12	M22997 ∞	Plug	1
13	M8940 ∞	Steel Ball, 1/4" Diameter	1
14	M29612-01 ⊕	Output Filter	1
15	M12461-32	Screw, #10-32 x 1 1/8" (50/55/60)	6
	M12461-31	Screw, #10-32 x 1" (40/70)	6
16	103676-01	Nylon Elbow, 90°	1
17	M8643-2**	Blade (50/55/60)	4
	M8643***	Blade (40/70)	4
18	FHPF3-6C	Screw, #10-32 x 3/4" (50/55/60)	2
	FHPF3-5C	Screw, #10-32 x 5/8" (40/70)	2
19	105780-01	Plastic Cap	1

** Included in Rotor Kit (Part No. HA3005)

*** Included in Rotor Kit (Part No. HA3004)

⊕ Included in Filter Kit (Part No. HA3014)

∞ Included in Pump Adjustment Kit (Part No. HA3020)

ILLUSTRATED PARTS BREAKDOWN

MOTOR AND PUMP ASSEMBLY FOR 110/115/155/165 MODELS

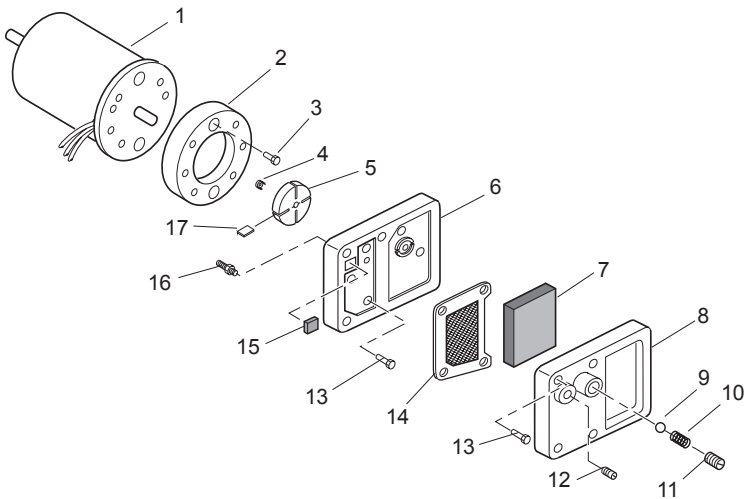

KEY			
NO.	PART NO.	DESCRIPTION	QTY.
1	102001-30	Motor	1
2	079975-02	Pump Body	1
3	FHPF3-5C	Screw, #10-32 x 5/8"	2
4	M22009**	Rotor Insert	1
5	M22456-1**	Pump Rotor	1
6	M50545	Pump End Cover	1
7	M12179***	Intake Filter	1
8	M16545	Filter End Cover	1
9	M8940∞	Steel Ball, 1/4" Diameter	1
10	M10993-1∞	Relief Spring	1
11	M27694∞	Adjusting Screw	1
12	M22997∞	Plug	1
13	M12461-31	Screw, #10-32 x 1"	10
14	M12244-1***	Output Filter	1
15	M11637***	Lint Filter	1
16	104096-01	Fitting, Straight Nylon Barb	1
17	M8643**	Blade	4

** Included in Rotor Kit (Part No. HA3004)
 *** Included in Filter Kit (Part No. HA3017)
 ∞ Included in Pump Adjustment Kit (Part No. HA3020)

ILLUSTRATED PARTS BREAKDOWN

MOTOR AND PUMP ASSEMBLY FOR 200 MODELS

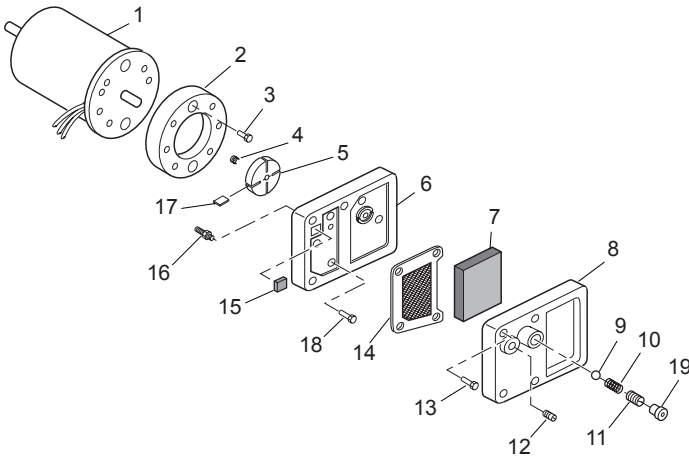

KEY

NO.	PART NO.	DESCRIPTION	QTY.
1	102001-27	Motor	1
2	079975-03	Pump Body	1
3	FHPF3-6C	Screw, #10-32 x 5/8"	2
4	M22009**	Rotor Insert	1
5	M22456-2**	Pump Rotor	1
6	M50545	Pump End Cover	1
7	M12179***	Intake Filter	1
8	M16545	Filter End Cover	1
9	M8940∞	Steel Ball, 1/4" Diameter	1
10	M10993-1∞	Relief Spring	1
11	M27694∞	Adjusting Screw	1
12	M22997∞	Plug	1
13	M12461-31	Screw, #10-32 x 1"	4
14	M12244-1***	Output Filter	1
15	M11637***	Lint Filter	1
16	M50820-02	Barb Fitting	1
17	M8643-2**	Blade	4
18	M12461-32	Screw, #10-32 x 1.12"	6
19	105780-01	Plastic Cap	1

*** Included in Filter Kit (Part No. HA3017)

** Included in Rotor Kit (Part No. HA3005)

∞ Included in Pump Adjustment Kit (Part No. HA3020)

ILLUSTRATED PARTS BREAKDOWN

WHEELS AND HANDLE PARTS LIST

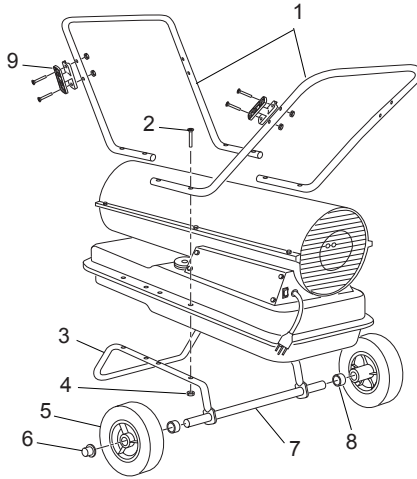

KEY

NO.	PART NO.	DESCRIPTION	QTY.
1	HA2303	Handle (110/115)	2 (If Equipped)
	HA2304	Handle (155/165/200)	2 (If Equipped)
2	M12345-33	Screw, #10-24 x 1 3/4"	6 or 8
3	M12342-3	Wheel Support Frame (110/115)	1
	M12831-5	Wheel Support Frame (155/165/200)	1
4	NTC-3BZ	Hex Nut, #10-24	6 or 8
5	107426-01	Wheel Kit (110/115) (Contains 2 Wheels and Cap Nuts)	1
	113326-01	Pneumatic Wheel Kit (155/165/200) (Contains 2 Wheels, Cap Nuts, & Spacers)	1
6	M28526	Cap Nut	2
7	M51015-01	Axle (110/115)	1
	M16801-5	Axle (155/165/200)	1
8	113497-01	Wheel Spacer (155/165/200 only)	2
9	113193-01	Cord Cleat Kit (Contains 2 Cleats, 4 Nuts and 4 Bolts)	1 (If Equipped)

REPLACEMENT PARTS

Note: Use only original replacement parts. This will protect your warranty coverage for parts replaced under warranty.

PARTS UNDER WARRANTY

Contact authorized dealers of this product. If they can't supply original replacement part(s), call DESA Heating Products' Technical Service Dept. at 1-866-672-6040.

When calling DESA Heating Products, have ready:

- your name
- your address
- model and serial numbers of your heater
- how heater was malfunctioning
- purchase date

Usually, we will ask you to return the part to the factory.

PARTS NOT UNDER WARRANTY

Contact authorized dealers of this product. If they can't supply original replacement part(s), call DESA Heating Products at 1-866-672-6040 for referral information. Parts dealers are listed in the Authorized Service Center booklet supplied with heater.

When calling DESA Heating Products, have ready:

- model and serial numbers of your heater
- the replacement part number

TECHNICAL SERVICE

You may have further questions about installation, operation, or troubleshooting. If so, contact DESA Heating Products' Technical Service Department at 1-866-672-6040. When calling please have your model and serial numbers of your heater ready.

You can also visit DESA Heating Products' technical services web site at www.desatech.com.

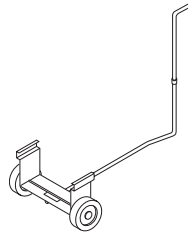

ACCESSORIES

Purchase accessories and parts from your nearest dealer or service center. If they can not supply these accessories or parts, either contact your nearest parts dealer or DESA Heating Products at 1-866-672-6040 for referral information. Parts Centrals are listed in the Authorized Service Center booklet supplied with heater.

STANDARD WHEELS AND HANDLE KIT HA1206

For 40/50/55/60/70,000 Btu Models. Makes heater even more portable and convenient. Easy to assemble.

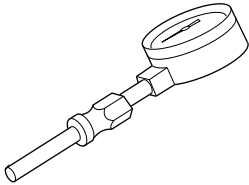

AIR GAUGE KIT - HA1180

For all models. Special tool to check pump pressure.

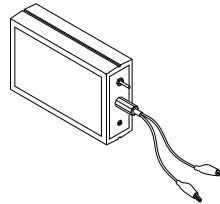

IGNITION CONTROL ASSEMBLY/ PHOTOCELL TESTER - HA1170

Special tool used to test the ignition control assembly and photocell.

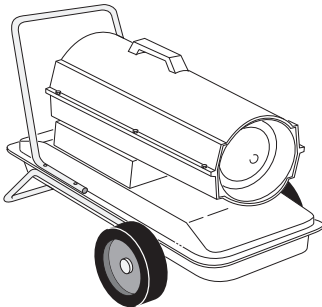

HEAVY DUTY WHEELS AND HANDLE KIT - HA1202

For 40/50/55/60/70,000 Btu Models. For heavy duty applications. Makes your heater even more portable and convenient.

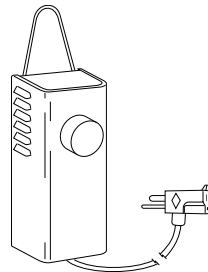

THERMOSTAT KIT - HA1210

Keeps your building at the temperature you select day and night. Helps economize on fuel.

WARRANTY AND REPAIR SERVICE

LIMITED WARRANTIES FOR NEW AND FACTORY RECONDITIONED PRODUCTS

New Products: DESA Heating Products warrants this heater and any parts thereof, to be free of defects in materials and workmanship for one (1) year from the date of first purchase, when operated and maintained in accordance with the manufacturer's instructions. These warranties are extended only to the original retail purchaser, when proof of purchase is provided.

Factory Reconditioned Heaters: DESA Heating Products warrants this factory reconditioned heater and any parts thereof, to be free of defects in materials and workmanship for thirty (30) days from the date of first purchase, when operated and maintained in accordance with the manufacturer's instructions. These warranties are extended only to the original retail purchaser, when proof of purchase is provided.

This warranty covers only the cost of parts and labor required to restore the product to proper operating condition. Transportation and incidental costs associated with warranty repairs are not reimbursable under this warranty.

Warranty service is available only through authorized dealers and service centers.

This warranty does not cover defects resulting from misuse, abuse, negligence, accidents, lack of proper maintenance, normal wear, alteration, modification, tampering, contaminated fuels, repair using improper parts, or repair by anyone other than an authorized dealer or service center. Routine maintenance is the responsibility of the owner.

THIS EXPRESS WARRANTY IS GIVEN IN LIEU OF ANY OTHER WARRANTY EITHER EXPRESSED OR IMPLIED, INCLUDING WARRANTIES OF MERCHANTABILITY AND FITNESS FOR A PARTICULAR PURPOSE.

DESA Heating Products assumes no responsibility for indirect, incidental or consequential damages. Some states do not allow the exclusion or limitation of incidental or consequential damages or limitations or exclusions may not apply to you. This Limited Warranty gives you specific legal rights and you may also have other rights which vary from state to state.

WARRANTY SERVICE

Should your heater require service, return it to your nearest authorized service center. Proof of purchase must be presented with the heater. The heater will be inspected. A defect may be caused by faulty materials or workmanship. If so, DESA Heating Products will repair or replace the heater without charge.

REPAIR SERVICE

Return the heater to your nearest authorized service center. Each Service Center is independently owned and operated. Repairs not covered by the warranty will be billed at standard prices. We reserve the right to amend these specifications at any time without notice.

Illustrated parts lists can be obtained free of charge. Send a self addressed stamped envelope to the address listed below. List the heater model number and the date located in the lower right corner of this page. A service manual may be purchased from the address listed below. Send a check for \$5.00 payable to DESA Heating Products.

When writing for information regarding your heater, be sure to include the model number and serial number as shown on the model plate.

For more information about this warranty, write:



2701 Industrial Drive
P.O. Box 90004
Bowling Green, KY 42102-9004
www.desatech.com



118536 01
NOT A UPC