

H·E·R·O

Industries

AIRLESS SPRAY EQUIPMENT

300GSD

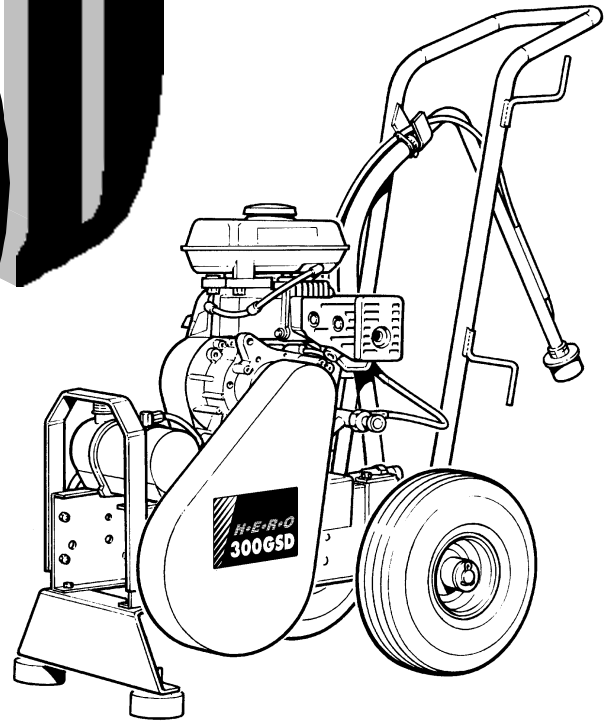

**NEW "B" SERIES
HYDRAPULSE**

**BEGINNING AT
SERIAL NUMBER
310313**

SAFETY, OPERATING AND MAINTENANCE INSTRUCTIONS AND PARTS LIST

Do Not attempt to operate this machine until you have read and understand **ALL** safety precautions and operating instructions. Equipment and chemicals when used improperly can be dangerous

H.E.R.O. WARRANTY

H.E.R.O. INDUSTRIES, guarantees this airless pump to be free of defects in materials and workmanship to the original owner, for a period of one full year from the date of purchase.

The warranty entitles the owner to parts replacement at no charge. The parts replacement warranty is valid for any necessary replacement, whither caused by material or workmanship defect or simple wear. The hydrapulse membrane (part# 4-04-22-4500) is warranted for LIFE. Installation costs for the hydrapulse membrane is provided for the first 12 months only.

H.E.R.O. Industries offers no warranty on the intake ball, outgo ball, drive belt, hoses, gun or accessories, plastic, rubber, other soft goods or motor used in or supplied with the H.E.R.O. sprayer.

Motor, accessories, etc., which are supplied by other manufacturers and are attached to or supplied with the H.E.R.O. airless pump, are warranted only to the extent that these parts are warranted by their respective manufacturers. Warranty claims must be made directly to such manufacturers or their local authorized service depots.

The warranty is only applicable to the original purchaser and the equipment has been properly used, operated and maintained in accordance with all instructions, precautions and warnings contained in this manual. For the purpose of this warranty, damage resulting from accident, abuse, improper cleaning or operation, fire, flood, or Act of God, is not covered.

H.E.R.O.'s liability is limited to replacing parts found to be defective or worn and does not include; transportation costs, damage or other expenses of any kind incurred in connection with the purchase and use of this sprayer.

Repairs claimed under warranty must be performed at an authorized H.E.R.O. Service Center, using only genuine H.E.R.O. parts. Parts necessary under warranty claim will be supplied by your local H.E.R.O. Service Center.

DO NOT return worn parts to factory without authorization. To qualify for the warranty, the warranty card (attached to this page) supplied with this H. E.R.O. airless pump, must be completed with equipment serial number and signed by the purchaser, and postmarked within ten (10) days of purchase.

TABLE OF CONTENTS

For greatest user satisfaction, please familiarize yourself with all maintenance and operational instructions

Important Safety Precautions	3-4
Introduction	5
Operating Instructions	5
Setting Up To Spray	6-7
Flushing The Unit	8
Special Notes.....	9
Airless Spray Painting Suggestions	10-12
Trouble Shooting.....	13-21
Hydrapulse Membrane Replacement	22
Intake Seat Replacement	23
Piston Repairs	24-25
Outgo Valve	26
Prime Valve Repairs	27
Pressure Control Valve Repairs	28
Accessories.....	29
Parts List And Descriptions	30-34
Exploded Unit Diagram.....	35-36

IMPORTANT

NOTE: AS WITH ALL MECHANICAL EQUIPMENT, PROPER OPERATING AND MAINTENANCE PROCEDURES ARE REQUIRED TO KEEP YOUR H.E.R.O. AIRLESS PUMP PERFORMING TO YOUR SATISFACTION. THE FOLLOWING SAFETY, OPERATING AND MAINTENANCE INSTRUCTIONS ARE IMPORTANT.

Read and understand this manual completely, especially with regard to all safety precautions. Read and follow instructions on all warning labels on your equipment. Keep the warning labels clean and readable at all times. Order new labels from your local distributor or from H.E.R.O. Industries Ltd. if needed.

The manufacturer shall not be responsible for any loss, damages, or injury of any kind or nature whatsoever resulting from the use of the equipment other than in strict compliance with the instructions, cautions and warnings contained in this operating and instruction manual and as displayed on the face of the equipment.

This system is capable of producing 2400 psi. (spray pressure). To avoid rupture and injury DO NOT operate this pump with components rated less than 3000 psi. working pressure (including but not limited to spray guns, hose and connections).

Before servicing, cleaning or removing of any part, shut off power and relieve pressure.

IMPORTANT SAFETY PRECAUTIONS

WARNING

NEVER PLACE FINGERS NEAR SPRAY TIP OF GUN. NEVER POINT GUN TOWARD ANY PART OF YOUR BODY, OR THAT OF ANY OTHER PERSON. MATERIAL ISSUING FROM THE SPRAY TIP IS AT HIGH PRESSURE. IF FINGERS, OR ANY PART OF THE BODY ARE PLACED NEAR THE TIP OF THE SPRAY GUN, IT IS POSSIBLE THAT THE SPRAY COULD BREAK THE SKIN AND INJECT SOME OF THE SPRAY MATERIAL. IF INJURY DOES OCCUR, SEEK THE IMMEDIATE ATTENTION OF A MEDICAL DOCTOR. BE PREPARED TO INFORM THE DOCTOR WHAT FLUID WAS INJECTED, IF THE INJURY IS OF AN INJECTION NATURE. EQUIPMENT AND CHEMICALS WHEN USED IMPROPERLY CAN BE DANGEROUS!

- NEVER** place any part of the body in front of the spray tip or aim the gun toward any part of the body.
- NEVER** point the gun toward any individual.
- NEVER** treat any injury as a simple cut. If injury does occur, seek immediate medical attention. Be prepared to inform the doctor what fluid was injected.
- NEVER** allow another person to use the sprayer unless he is thoroughly instructed on its operation and has read all safety precautions in this manual and all safety warning labels attached to unit.
- NEVER** use around children.
- NEVER** attempt to perform any maintenance or service on any part of the unit spray system without first;
 1. Turn off the engine.
 2. Turn the engine switch to "OFF" position.
 3. Relieving all pressure in the pump by triggering the gun.
 4. Locking gun trigger in "LOCKED" position, with gun locked closed.
- NEVER** operate the sprayer without the tip guard complete and in place.
- NEVER** spray any material in the vicinity of open flame, pilot lights, electrical outlets or any other source of ignition.
- NEVER** spray volatile materials with flash points lower than 140 F (60 C).
- NEVER** attempt to stop any leakage in the paint line or at any fitting with your hand or any part of your body. Immediately shut off the unit should leakage occur.
- NEVER** allow paint hose to become kinked, or to vibrate against rough or sharp surfaces.
- NEVER** operate the unit at pressures higher than the pressure rating of the lowest rated component in the system, or at pressure higher than factory preset.
- NEVER** spray in an enclosed area. The spraying area must be well ventilated to safely remove chemical vapors.
- NEVER** operate the unit with worn or damaged accessories, or with accessories other than those supplied by H.E.R.O. Industries, unless the accessories have been first specifically approved in writing by H.E.R.O. Industries Ltd.
- NEVER** allow the unit to be serviced or repaired anywhere other than an authorized H.E.R.O. Service Center, or with other than genuine H.E.R.O. parts or components.
- NEVER** leave unit unattended without first shutting off, triggering the gun to relieve all pump pressure, and setting the trigger lock on gun in "LOCKED" position, with gun locked closed.

ALWAYS

- ALWAYS** follow H.E.R.O. recommendations for operation and safety completely.

- ☑ **ALWAYS** set trigger lock on gun in "LOCKED" position when not in use, with gun locked close.
- ☑ **ALWAYS** check connections and fittings for tightness before operating the unit.
- ☑ **ALWAYS** locate the unit in a well ventilated area a minimum of 25 feet from the spray area.
- ☑ **ALWAYS** ground the unit, the paint containers, and the object being sprayed to eliminate static discharge. Ensure that all these objects remain grounded throughout the entire spraying operation.
- ☑ **ALWAYS** use accessories and components approved for at least 3000 psi (working pressure) in the spraying system.
- ☑ **ALWAYS** use accessories and components supplied by H.E.R.O. Industries Ltd., or specifically approved in writing by H.E.R.O. Industries Ltd. on with the unit.
- ☑ **ALWAYS** examine accessories for wear or damage before operating the unit.
- ☑ **ALWAYS** use lowest possible pressure when flushing and cleaning the unit, and hold the gun firmly against a metal container to reduce static discharge possibility.
- ☑ **ALWAYS** wear a face filter mask when operating the unit.
- ☑ **ALWAYS ;**
 1. Turn off the engine.
 2. Turn the engine switch to "OFF" position.
 3. Relieve all pressure in the pump by triggering the gun.
 4. Lock gun trigger in "LOCKED" position, with gun locked closed before attempting to perform any maintenance or service on any part of the unit spray system.
- ☑ **ALWAYS** wear safety glasses when operating the unit.
- ☑ **ALWAYS** ensure fire extinguishing equipment is readily available and properly maintained in the spray area.
- ☑ **ALWAYS** observe good housekeeping and keep the spray area free from obstructions.
- ☑ **ALWAYS** be aware that certain chemicals may react with aluminum, carbide, or other components in the pump system. Read the manufacturer's label on all materials to be sprayed, and follow the manufacturer's recommendations. If in doubt, consult your material supplier to be sure.

H.E.R.O. AIRLESS SPRAY PAINTING

Welcome to the world of H.E.R.O. airless paint spraying. We are sure you will enjoy owning and operating your new H.E.R.O. model 300GSD. With H.E.R.O. airless spray equipment you will avoid the

inconvenience and mess of overspray. You are spraying paint, not air, and the paint is driven to the painting surface in a clean, fan shaped spray which penetrates all cracks and corners. To attain these results, you must adjust the pressure as low as possible. We recommend that you become familiar with your H.E.R.O. unit. Discuss with your dealer the useful accessory items he has to offer - various types of tips, extension poles for hard to reach areas, extra hose, etc. Use of accessory items is often the difference between a good job and an excellent one!

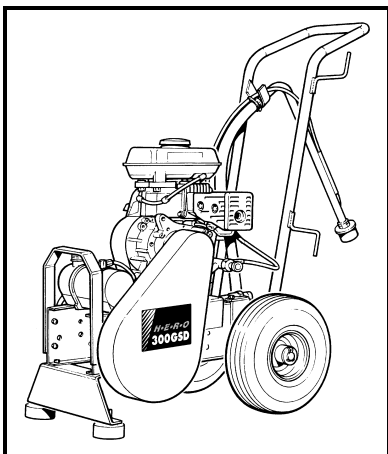

**1997
HYDRAPULSE
“B” VERSION
BEGINNING AT
SERIAL NUMBER
310313**

OPERATING INSTRUCTIONS

WARNING

Do not attempt to operate this machine until you have read and understood all safety precautions and operating instructions. Equipment and chemicals when used improperly can be dangerous.

Your H.E.R.O. airless sprayer has been fully factory tested prior to shipment.

BEFORE STARTING YOUR H.E.R.O. PUMP....

CHECK to ensure that the shipping seal has been removed from under the cap on the hydraulic tank. Hydraulic tank should be at least 3/4 full of H.E.R.O. LVO hydraulic fluid.

CHECK all fittings and connections in the pump system, hose, and gun to ensure that they are tight.

CHECK to ensure that there is a spray tip in the gun, and that the tip is the correct size for the coating you are to spray. (There are various tips available, for each type of coating or configuration. See " Airless Spray Tip " on page 11 , for proper tip selection.

CHECK to ensure that you have H.E.R.O. strainer bags, H.E.R.O. Wonder Wash, appropriate thinner for the paint, a waste container, and any other accessories you may require for the job.

READ THIS MANUAL THOROUGHLY.

READ THE HONDA ENGINE MANUAL SUPPLIED WITH THE UNIT. FOLLOW ALL THEIR RECOMMENDED PROCEDURES FOR “START-UP” AND OPERATION

SETTING UP TO SPRAY

1. Remove unit from shipping carton.
2. Attach intake siphon assembly (ref# 1) to intake elbow (ref# 8). The intake elbow provides a swiveling connection during assembly only. Two wrenches are required to tighten these fittings. When sufficiently tightened the siphon hose will no longer swivel or move, as such, ensure the siphon hose is positioned in the desired direction prior to making the final tightening. The desired position is straight back from the intake. Use caution to avoid over tightening which may result in cracked or broken fittings.

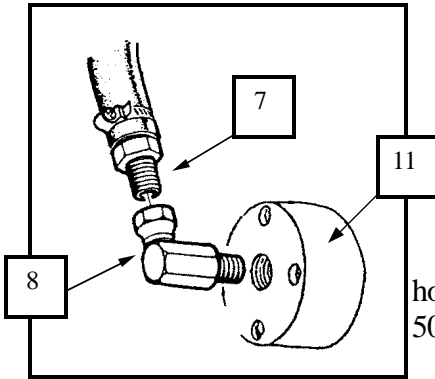

3. Attach prime valve hose barb (ref# 52) to prime valve hose barb (ref# 52).

hose (ref# 50). Secure

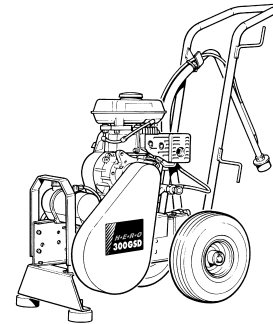

51) to prime with clamp

4. Attach paint hose to outgo tee (ref# 35).
5. Attach gun to paint hose. **NOTE;** *Spray tip and tip guard should be attached to gun prior to attaching to hose.*

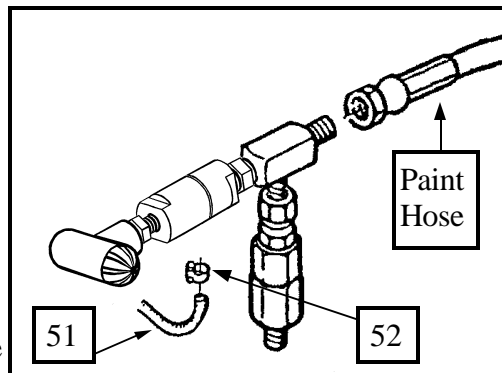

siphon assembly

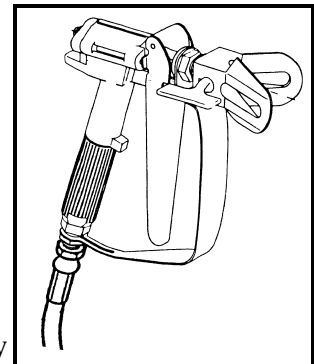

6. Place intake siphon assembly into a clean 5 gallon pail.

7. Install strainer bag (accessory item-5GAL SB) in pail and secure with large rubber band (accessory item 106). **NOTE;** *Strainer bag must remain 4 inches from the bottom of pail*
8. Trigger gun to release any pressure in the unit. Use extreme caution to ensure that the gun is not directed towards anyone or any object which may be damaged. **NOTE;** *Unit may contain storage solution.*
9. To remove storage solution, add one gallon of thinner, compatible with the type of paint to be used, to the siphon pail.

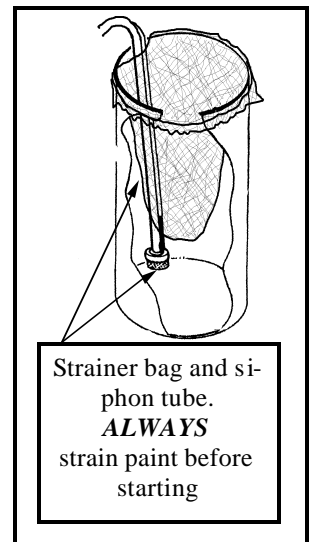

Strainer bag and siphon tube.
ALWAYS
strain paint before starting

SETTING UP TO SPRAY - CONTINUED

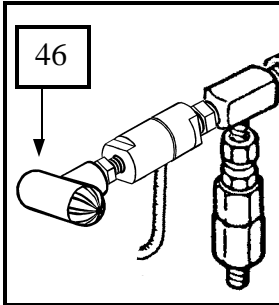
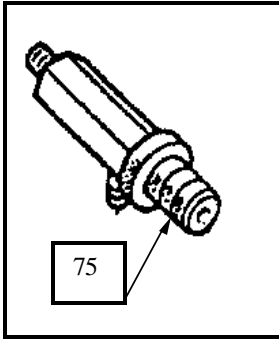

10. Turn pressure control knob (ref# 75) counter clockwise to lowest pressure setting.
11. Observe and perform all pre-operation checks as required by the engine manufacturer, (Honda). See your Honda owner's manual.
12. Start engine. See Honda owner's manual for correct procedures.
13. Turn prime valve knob (ref# 46) counter clockwise until fully open. Allow thinner to circulate back into the siphon pail for a few minutes. Then turn the prime valve knob clockwise to close the valve (close tightly), and direct the flow to the paint hose and gun. Leave the pressure setting low.
14. Trigger gun into a waste container.
15. Remove rinse / prime fluid and pour paint through strainer bag into siphon pail.
16. Repeat step 13, until paint flows freely.
NOTE; *Never turn prime valve back to "prime" position when the unit is under pressure.*
NOTE: *The thicker paint will require a longer time to complete the initial prime circulation through the prime valve. Leave the valve in the prime position to ensure the complete removal of all air and pre-prime fluid. Several minutes may be required, particularly with thicker viscosity products.*
17. Spray a test pattern. Begin by spraying a test pattern onto old newspaper or other scrap material.
18. Increase the pressure, slowly at first, by turning the pressure control knob clockwise. Continue increasing the pressure until the spray pattern is uniformed from top to bottom, with no heavy areas. Secure pressure control setting, by turning the silver lock ring (ref# 77) counter clockwise until snugly against the face of the pressure control knob. If heavy areas are still visible at maximum pressure setting, thin the paint with the correct thinner, according to the paint manufacturer's recommendations.
19. Spray paint.

Paint Straining

*It is recommended that all products entering the sprayer, be pre-strained to remove any large particles and contaminants, **BEFORE** they are drawn into the sprayer. The strainer bag should remain in place throughout the painting operation. This will prevent foreign matter from falling into the bucket and contaminating the previously strained paint. The gun filter should not be relied upon to do all the paint filtration. Any dirt, grime or other undesirable particles which reach the gun filter have passed through the entire paint pump and have possibly created unnecessary damage and inconvenience. Always strain the paint before siphoning.*

FLUSHING THE UNIT AT SHUTDOWN OR COLOR CHANGE

If shutting down for a short period of time, it is sufficient to trigger the gun to relieve pressure. Then set the safety lock on gun to "locked" position with the gun locked closed and immerse the gun in a container of the correct thinner for the paint you are spraying.

1. Remove spray tip from gun.
2. Turn pressure control knob counter clockwise to low pressure setting. Only use sufficient pressure to allow material to move through the sprayer. **DO NOT** operate at or near full pressure.
3. Remove siphon assembly from paint container.
4. Trigger gun, back into paint container, until unit runs dry.
NOTE: Pump and spray hose will continue to contain paint. This paint may be recovered by placing prime hose into paint container and draining the remainder while re-priming with cleaning fluid. See step 5* and 6*.
5. Place siphon assembly in container of correct thinner, for the spray product being used,, and prime the pump as shown in step 13, of "Spraying". *See special notes from step 4. Allow thinner to circulate back into the container for a few minutes to flush the prime valve.
6. Close prime valve.
7. Trigger gun into paint container until thinner comes through. *See special notes from step 4. Re-direct flow into waste container and continue spraying until thinner runs clear. Heavily soiled thinners may have to be changed to complete cleaning job.
8. Lift siphon assembly and allow pump to run dry.
9. Repeat procedure using a gallon of **H.E.R.O. Equipment Wonder Wash** solution. If not using Wonder Wash, unit **must not** be stored with water. Only store with a non corrosive material (Paint thinner, solvent).
10. Switch unit "off" and trigger gun to relieve remaining pressure.
11. Remove and rinse gun handle filter in correct thinner.

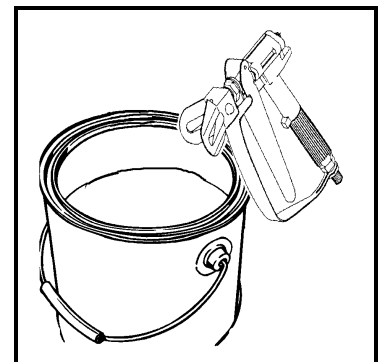
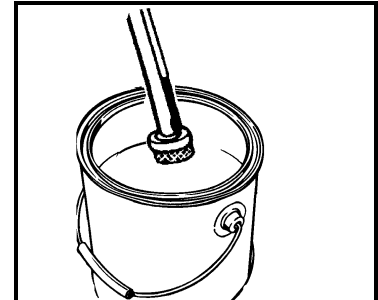
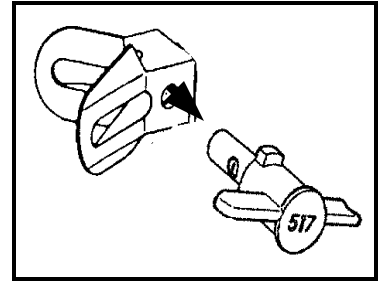

SPECIAL STORAGE INSTRUCTIONS

In areas where the sprayer is **NOT** used 12 months of the year, special preparations must be used for winter or off season storage. Because solvents evaporate quickly, they should not be used for long term storage. A petroleum based solution (solvent and oil) should be used as an extended storage material. **DO NOT** allow storage solution to freeze in the sprayer.

H.E.R.O. Equipment Wonder Wash, available from your H.E.R.O. distributor, will provide the added cleaning benefits of solvent at a much lower cost. Suitable as a short term (1-2 days) storage solution only

H.E.R.O. Industries Ltd.

WONDER WASH

NET WEIGHT 1½ OUNCES 42 GRAMS
ADD CONTENTS TO 1 GALLON OF WATER

- Cleans, flushes and protects Paint Spray Equipment from corrosion
- Lubricates valves while cleaning
- Economically replaces solvent for many cleaning applications
- Cleaning compound for use with Pressure Washing Systems
- CAUTION: Read all directions on back panel before using.

2719 Lake City Way, Burnaby, B.C. V5H 2Z6

WONDER WASH

DIRECTIONS
Mix contents of this package with 1 gallon of water. Use as a final flush for pumps and equipment. Oil base coatings must first be flushed with their recommended thinner. After flushing leave solution in the system. Inhibits rust and corrosion, lubricates valves, keeps paint particles suspended.
Also suitable for use as a cleaning solution for pressure washing. Concentration can be increased for heavy degreasing using hot water.

CAUTION
Strong alkaline solution. Can cause eye and skin burns. Avoid immersing hands.
In case of contact, flush eyes immediately with water for at least 15 minutes.
Call a physician.
Wash thoroughly after handling.
If swallowed, do not induce vomiting. Give one ounce of vinegar and an equal volume of water.
Call a physician.

PLEASE NOTE: This product is much more concentrated than comparable competitive products and should be handled with care to avoid skin burns.

SPECIAL NOTES AND INSTRUCTIONS

NEVER LEAVE THE UNIT UNDER PRESSURE WHEN NOT SPRAYING (ENGINE TURNED OFF). RELIEVE PRESSURE BY TRIGGERING GUN. NEVER STORE THE UNIT WITH PAINT OR WATER IN THE PUMP SYSTEM, EVEN OVERNIGHT.

- ☒ NEVER attempt to start the engine when the unit is under pressure. Relieve pressure and follow instructions in "Setting up to spray"
- ☒ Avoid operating the unit while tilted. Keeping it level assures greater operating efficiency.
- ☒ Always follow flushing and cleaning instructions exactly.
- ☒ In hot weather, locate unit in shade.
- ☒ Regularly check the level of H.E.R.O. LVO hydraulic fluid in the hydraulic tank. It should be kept near full, top up as needed with only genuine H.E.R.O. LVO hydraulic fluid.
- ☒ Crankshaft eccentric bearing should be greased at regular intervals consistent with hours of use. Use MO-2 grease (i.e. common auto grease) approximately every 10 hours of operation.
- ☒ A minimum 50' and a maximum of 300' of airless spray hose may be used.
NOTE: 50' x 3/8" paint hose (part # 117) should be used for every 50' x 1/4" paint hose (part # 114) over 100'.
100' total length of paint hose = 2 of 50' x 1/4" paint hose.
150' total length of paint hose = 2 of 50' x 1/4" paint hose and 1 of 50' x 3/8 paint hose.
200' total length of paint hose = 2 of 50' x 1/4" paint hose and 2 of 50' x 3/8 paint hose.
250' total length of paint hose = 3 of 50' x 1/4" paint hose and 2 of 50' x 3/8 paint hose.
300' total length of paint hose = 3 of 50' x 1/4" paint hose and 3 of 50' x 3/8 paint hose.
- ☒ Product viscosity, altitude (feet above sea level) and vertical reach can effect pump performance and special accessories may be required. Product viscosity may have to be further reduced at higher elevations. The larger diameter 3/8" paint hose should be used.
- ☒ Check drive belt (part# 66/100) tension frequently. The belt will stretch with use, and should be adjusted after 20 hours of operation and again after 50 hours. Periodic checks after 50 hours should be made. Failure of the drive belt is not covered by the equipment warranty, so proper maintenance of the belt is important.
- ☒ Regularly check fittings, bolts, nuts and connections for damage. Tighten, adjust or replace as required.
- ☒ Check crankshaft alignment often. An out of alignment crankshaft will cause the damage to the eccentric bearing.

GAS ENGINE

- ☒ Check the engine oil level daily. Top up only with the manufacturer's recommended oil. Running the engine with insufficient oil can cause serious engine damage.
- ☒ Check the engine air cleaner daily. **NEVER** operate without an air cleaner.
- ☒ Use only UNLEADED or lowleaded gasoline.
- ☒ The engine requires regular operation and should not be stored for prolonged periods without operating. Run for a minimum 15 minutes each week while in storage.
- ☒ Remove gas before storing.
- ☒ Have the engine professionally serviced by an approved service technician on a regular bases as recommended by the manufacturer (Honda).

AIRLESS SPRAY PAINTING

SUGGESTIONS AND TECHNIQUE

A good airless spray application is the result of many factors. Surface preparation, which includes cleaning and degreasing, priming, material compatibility, quality finish product and correct application technique, are all important to the finished results.

The key to all good applications is a good spray gun technique. The finished results are what the client will look at and base his opinion on. Your skill and abilities are as important as good equipment and good paint. Proper application techniques can easily be learned by using the following simple guidelines. If you are not familiar with the basic spray techniques we recommend that you study this portion of the manual and practice the techniques shown. Practice your technique on scrap cardboard or old newspaper until you feel confident.

FOR EXCELLENT RESULTS, READ AND PRACTICE THESE TECHNIQUES

1. Always strain all paint through a H.E.R.O. strainer bag.
The most common reason for airless sprayers to malfunction is foreign matter jamming the valves or plugging the tip. Always strain the paint before putting through the pump.
2. Always spray at the lowest pressure setting which will provide a uniform spray fan. (fig. 1, page 10)
Adjust pressure control knob so that paint is completely atomized. Insufficient pressure will result in "tailing". Too much pressure will result in excess fog and over spray, excess tip wear, and increased sprayer wear and tear. See setting up to spray, page 5.
3. Always spray at right angles to the surface being sprayed. (fig. 2, page 10)
Angling or arcing the nozzle toward the surface will cause uneven coverage and excessive overspray.
4. Always hold spray gun 12-15 inches from spray surface. (fig. 3, page 10)
Too close and the fan width will be reduced and material will be applied too heavily (runs).
Too far from the surface and you will have excessive overspray and light coverage (transparent).
5. Always move the gun parallel to the surface being sprayed, at a consistent speed.
This avoids uneven coverage (thick or thin areas).
6. Always start the spray stroke before triggering the gun and release the trigger before completing the stroke. (fig. 4, page 10)
This avoids heavy build up of paint at either end of the spray stroke.
7. Always lap your spray pattern by one half. (fig. 5, page 10)
This assures full coverage of the surface being painted.

AIRLESS SPRAY PAINTING SUGGESTIONS AND TECHNIQUE

SPRAY TIP SELECTION

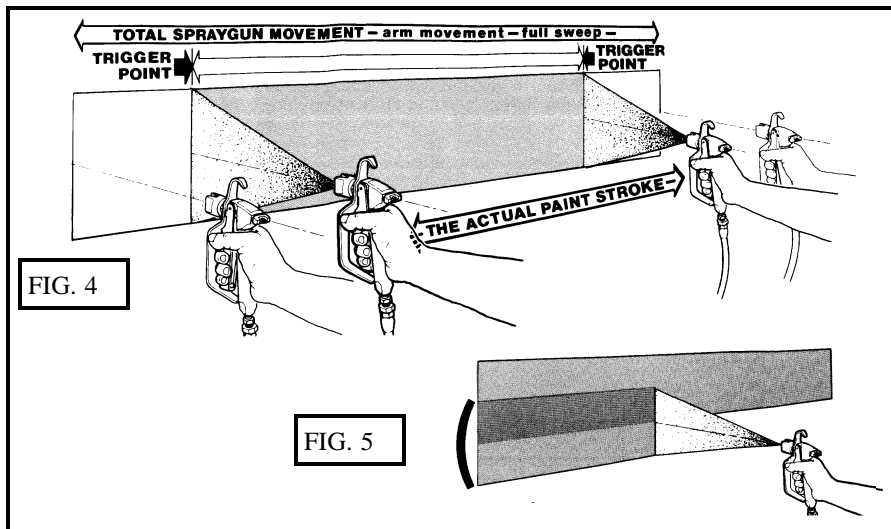
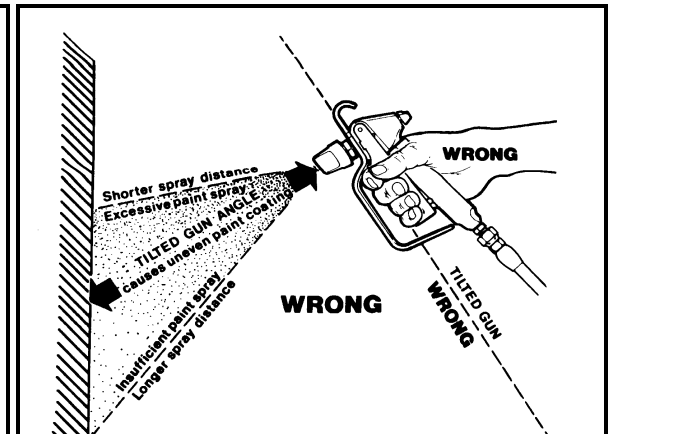
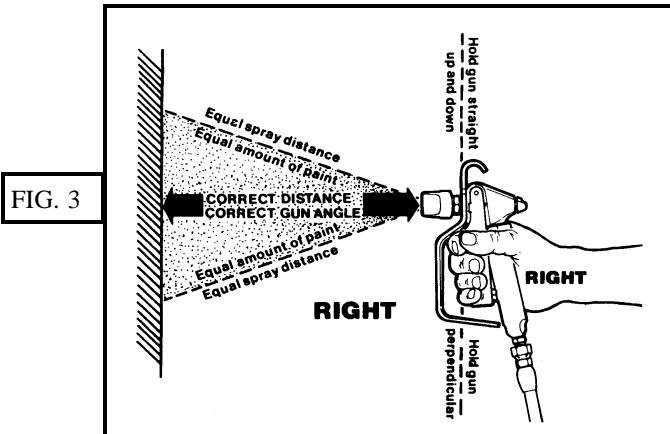
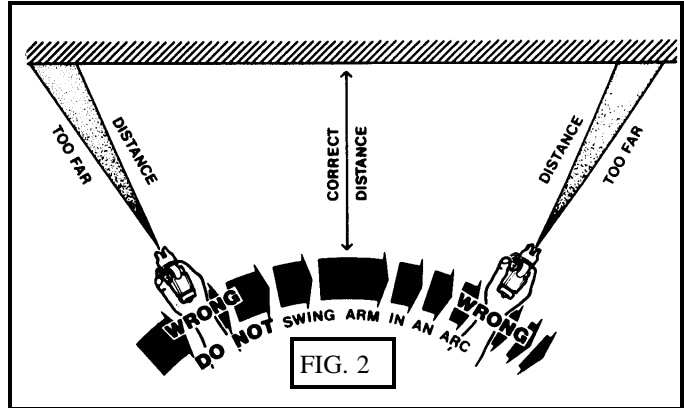
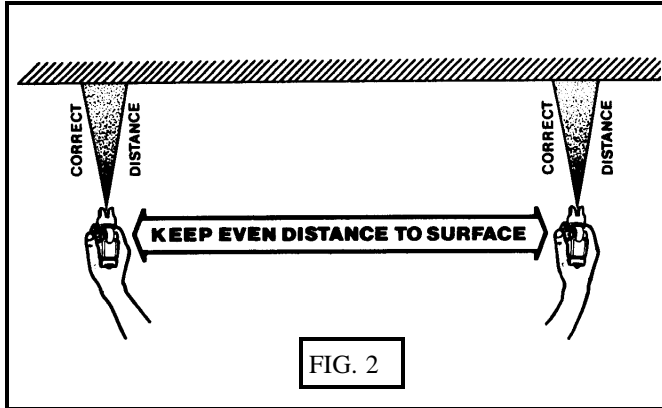
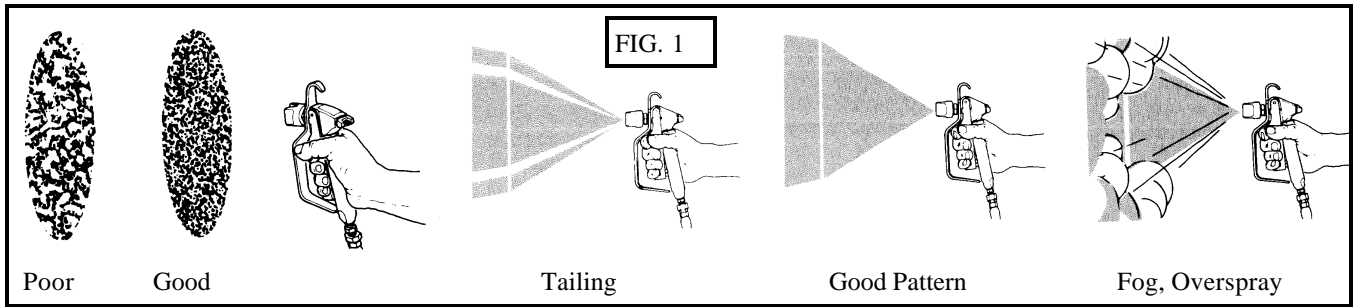

TIP SIZE FOR APPLICATION OF

.021	Exterior Latex on large unobstructed areas.(max. size allowed) (60 OZ.)
.018	Interior Latex, Exterior Latex, Shake Paint, Exterior Flat Paints. (46 OZ.)
.015	Alkyd Flat Enamel, Interior Latex, Semi-Gloss Enamel, Stains. (30 OZ.)
.013	Fine ground Gloss Enamels, and good quality Stains. (23 OZ.)
.011	Clear Varnishes and Lacquers. (15 OZ.)
.009	Clear Varnishes and Lacquers. (10 OZ.)

NOTE: The above volumes achieved with gun wide open for 1 minute and pump spraying at 2000psi. All volumes are approximate. To test worn tips, spray water through the tip at 2000 psi. for 1 minute. Spray into bucket and weigh amount (less weight of bucket). If it is substantially greater than what is listed above, then the tip should be discarded or reclassified. As a tip wears, the hole gets larger and the fan pattern becomes narrower.

ORIFICE SIZE

All tips are rated by the size of the orifice or bore size. The bore size is measured in thousandths of an inch (.018 = 18 thousandths of an inch). The size of tip required is based on the consistency of the material to be sprayed. The thicker the paint, the larger the tip size required. Always consult the product label or ask the paint retailer for the manufacturer's recommendations with regard to proper tip sizes.

FAN WIDTH

Fan width or pattern width is determined by the spray tip's "fan width" classification. This size is measured in inches, and is determined when spraying 12 inches from the spray surface. Various methods of noting the fan widths are used by tip manufacturers. Ask your distributor for assistance.

NOTE: Two tips having the same tip size, but different fan widths will deliver the same amount of paint over a different area (wider or narrower strip). A spray tip with a narrow pattern width makes it easy to spray in tight places. Use only good quality, high-pressure tungsten carbide spray tips.

SPRAY TIP REPLACEMENT

During use, especially with Latex paint, high pressure and material abrasion will cause the orifice to grow larger. As the orifice grows larger, the fan width grows smaller. Replace tips before they become excessively worn. Worn tips waste paint, cause overspray, make cutting in difficult, and decrease sprayer performance.

NOTE: When using Latex paint, a spray tip will wear at the rate of one size for approximately every 100 gallons of material sprayed.

*An excessively worn tip can be the cause of apparent operating problems with the unit. If a tip is worn past the aperture size which the unit can support, pulsation will become evident in the spray fan/pattern. Added strain is placed on the Hydrapulse membrane as it attempts to keep the spray pressure consistent. When the tip wears beyond .024, its is releasing more material than the unit is bringing in. The natural reserve of product in the paint chamber is reduced and harm to the membrane begins. ALWAYS check your tips for wear when trouble shooting the equipment.
The 300GSD can support up to a maximum of a one, like new - .024 tip.*

TROUBLESHOOTING

Hydraulic Energy Regulated Output (H.E.R.O.) is more than just our name, it is the bases for the operation of the pump. It is the regulation or control, of hydraulic energy, which allows the equipment to

build and then deliver or have an output of pressure. Once you have a basic understanding of the operation of the equipment and the effect created in one area and how it will effect operation in another area, you will be better able to diagnose and make repairs.

All H.E.R.O. hydropulse membrane pumps are made up of two (2) distinct pumps. The first, and most important pump is the hydraulic pump. The hydraulic system is made up of two valves, the hydraulic intake valve (ref# 66) and the hydraulic outgo valve, known as the hydraulic pressure control valve (ref# 74). The second pump is known as the paint or material pump. The paint system is made up of two basic valves, the paint intake valve assembly (ref# 11-18), paint outgo valve, (ref# 26). A third valve, known as a prime valve (ref# 36) is used during the priming procedure, (see "setting up to spray"). For correct operation, all five valves must be in good working condition. For this manual we will refer to the two systems as "hydraulic" and "paint".

At the center of these two pumps is the hydropulse membrane. The hydropulse membrane is a flexible nylon disc which transfers the energy (pressure) created by the hydraulic pump, to create energy (pressure) in the paint pump. The function of the hydropulse membrane is to create a barrier between the hydraulic oil and the spray material and transfer the energy created.

To fully understand and trouble shoot a H.E.R.O. pump, always keep in mind that "for every action, there is an opposite or corresponding re-action". For every action of the hydraulic intake valve (ref# 66), there is an opposite re-action of the hydraulic outgo valve (ref# 74). At the same time there are corresponding re-actions taking place within the paint pump. This means that as the hydraulic intake valve is opening, so is the corresponding paint intake valve, and while the hydraulic outgo valve is closing, so is the corresponding paint outgo valve. The operation and function of each valve is discussed at the end of this section.

For correct operation to begin, the hydraulic system must be fully primed and all air must be removed (see "**purging**" page 18). Operation begins with piston in the backward position (fig.# 2). At this point the hydraulic intake is open, while the hydraulic outgo valve is closed. The corresponding paint valves are in similar positions.

As the piston moves forward, it pushes hydraulic oil forward. This movement of oil causes the hydraulic intake valve to close and the hydropulse membrane to move forward (fig.# 1). The hydraulic outgo valve will remain closed until sufficient pressure is created to cause it to open. While the hydraulic valves are operating a corresponding re-action is taking place in the paint valves. The forward movement of the hydropulse membrane pushes the paint, causing the paint intake valve, (ref# 11-18) to close. The trapped paint requires a means of release, so it forces the outgo valve, (ref# 26), to open and paint flows to the gun.

TROUBLESHOOTING

The backward movement of the piston, creates a vacuum in the hydraulic system. This causes the hydraulic outgo valve to close and the hydraulic intake valve to open (fig# 1). Opening of the hydraulic

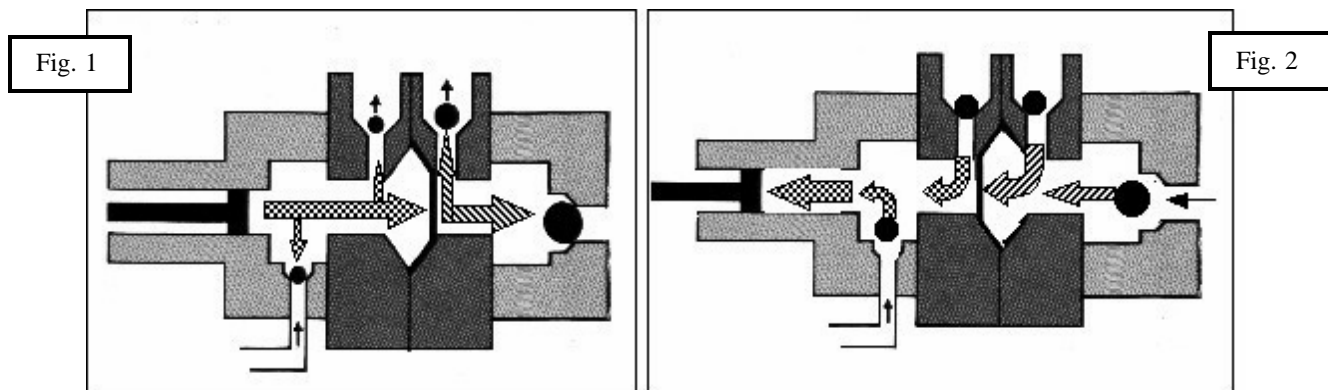

intake valve allows a new supply of hydraulic oil to enter the system, replacing the oil which was used on the forward stroke. Once again a corresponding re-action is taking place in the paint pump. The hydropulse membrane is being pulled backward by the hydropulse membrane spring, (ref# 56). The backward hydropulse membrane movement causes a vacuum in the paint pump. This vacuum causes the intake valve to open, allowing a new supply of paint to enter. The corresponding paint outgo valve is drawn closed by the vacuum created by the hydropulse membrane.

These operations are repeated at a rate of 750 times a minute. These continuously repeated actions draw paint into the pump, pressurize it, and then deliver it to the gun. The failure, of any one valve, to operate correctly will effect the overall equipment performance. Each of the five valves mentioned earlier, have an important function and will effect the overall performance of the unit if not performing correctly.

HYDRAULIC INTAKE VALVE (REF# 66, PART # 4-30)

The hydraulic intake valve, is a small vacuum valve which controls the hydraulic oil entering the hydraulic pump/cylinder area. Once the oil has past through the valve it is prevented from returning. The valve is commonly called a "one way check valve". Valve failure will result in the hydraulic pump being unable to build pressure, and the hydropulse membrane will stop moving. Spray pressure will cease.

HYDRAULIC OUTGO VALVE (REF# 74, PART# 4-27C)

The hydraulic outgo valve, better known as the "pressure control valve", is used to control the units operating pressure. The valve is fully adjustable from 0 psi. to 3000 psi. By turning the pressure control valve knob (ref# 75) clockwise the pressure is increased. The hydraulic pump continues to build at all times and must have a means of releasing this pressure. Pressure applied to the P.C. ball, (ref# 88) will keep it lodged in the P.C. seat (ref# 87) until the internal hydraulic oil pressure is sufficient to cause it to open. The point at which the oil is released is equal to the level set by the control knob. As components within the pressure control valve wear, the valve loses its ability to maintain or reach the required pressures (see "low static pressure").

PAINT INTAKE VALVE ASSEMBLY (REF# 11-18)

The paint intake valve is made up of eleven items, endcap (ref# 11), washer (ref# 12), seat (ref# 13) intake ball (ref# 14), spring (ref# 15), o-ring (ref# 16), ball guide (ref# 17), and ball stop (ref# 18). The intake valve controls the incoming flow of spray materials and is responsible for keeping them from returning to the source. The ball must be able to create a complete seal on the seat, otherwise pressure will be lost. A worn intake valve will permit correct static pressure, but supply lower spray pressure. A worn intake ball will become smaller in diameter and lose its ability to seal at the seat. A worn seat will develop a large step in the area where contact with the ball is made. This can cause the intake ball to distort in shape making the ball egg shaped. If the valve assembly becomes warm to the touch, this may be a sign of a loose or worn seat caused by wear or improper compression caused by a worn intake washer (ref# 12). The intake washer (ref# 12), acts as a compression washer insuring the seat (ref# 13) remains pressed into the endcap (ref# 11). The seat must remain firmly pressed into the endcap at all times, through the correct assembly of parts listed, and the correct bolt torque. Replace the intake washer (ref# 12) each time the endcap is removed. See page 23 for details.

TROUBLESHOOTING

PAINT OUTGO VALVE (REF# 26, PART# 4-611C)

The paint outgo valve monitors and controls the flow of spray materials as it leaves the sprayer. It also

works together with the paint intake valve, to build paint pressure as specified by the setting made by the hydraulic outgo valve (pressure control valve). A worn outgo valve will result in pulsation in the spray material and cause the paint hose to jump and vibrate vigorously.

PRIME VALVE (REF# 36, PART# 4-603)

The prime valve is used at the beginning and end of the spray operation (see "setting up to spray"). The function of the prime valve is to assist in removing air from the paint pump when beginning to spray. It is necessary to remove all air from the paint pump so that the spray material can replace it. The pump will function without the prime valve, however, the initial priming procedure would require considerably longer to complete. During the priming procedure the hydropulse membrane is exposed to its greatest amount of stress. Use of the prime valve and a lightweight thinner, which is compatible with the intended spray material, will reduce hydropulse membrane stress and reduce priming time. The prime valve will also allow you to remove any unused paint left in the pump and hose at the completion of a job. When the prime valve is open the material is pumped through the paint intake and outgo and back to the source by way of the prime valve. When closed, no material should be escaping from the prime valve return hose (ref# 51). If material escapes through the prime valve return hose, when the valve is closed, spray pressure at the gun will be reduced.

The solution to almost all problems can usually be found in the paint side valves. However, before performing any repair or looking further, the following are things which can cause an apparent sprayer failure, without any mechanical problem. ALWAYS check these items before proceeding.

1. Circuit breaker open or fuse blown
2. Engine fuel line closed.
3. Engine switch set to "OFF".
4. Spark plug wire loose or disconnected.
5. Pressure control knob loose or missing
6. Spray tip plugged.
7. Spray tip worn out.
8. Gun handle filter plugged.
9. Paint hose plugged.
10. Loose fitting or hole in siphon hose.
11. Intake siphon hose plugged.
12. Siphon screen missing or plugged.
13. Sprayer under pressure when restarting.
14. Strainer bag plugging siphon screen.

UNLESS YOU ARE KNOWLEDGEABLE ABOUT THE REPAIR OF HIGH PRESSURE EQUIPMENT, DO NOT ATTEMPT TO REPAIR AN AIRLESS SPRAYER YOURSELF. ALWAYS FOLLOW ALL SAFETY PRECAUTIONS.

TROUBLESHOOTING

PRESSURE TEST

To verify the operation of an airless sprayer, use of pressure gauge is required. A pressure gauge (min. 3000 psi) installed at the gun, using a new .021 tip, and not less than 50 feet of H.E.R.O. airless spray hose is

needed. If you do not have access to these items, your local H.E.R.O. authorized service center will be able to perform this test. Your model 300GSD is manufactured to perform at;

- 2650 psi -- Static pressure, with lock ring (ref# 77) on pressure control valve (ref# 74).
- 1950 psi -- Pressure drop, when gun trigger is squeezed.
- 2250 psi -- Spraying pressure, after recovery time.

If your unit is unable to perform to the above pressure levels consult the troubleshooting guide for the required repair procedure.

HYDRAPULSE MEMBRANE TEST

If your unit is disabled and you are unable to perform a pressure test, use the following procedures for determining the area to repair. This test will divide the two halves of the equipment (hydraulic from paint) and make identification of your solution easier to obtain. This test is commonly referred to as the "Hydrapulse membrane Test"

The solution to almost all problems can be found in the paint side valves, due to the increased wear from contact with the abrasive paint/spray materials. Intake valve (ref# 11-18), Outgo valve (ref# 26), and Prime valve (ref# 36) make up the three paint valves. Refer to pages where exploded views of these valves are shown. To eliminate the hydraulic side of the pump (piston side of hydrapulse membrane) as a source of problems;

1. Remove the intake valve end cap (ref# 11) by removing the four cap screws (ref# 9). The intake valve assembly, (ref# 11- 18), will generally come off as an entire assembly, requiring no further dismantling. If the ball guide (ref# 17) and ball stop (ref# 18), remain in the paint head, they can be pried free with a screwdriver.
 2. Start unit.
 3. Increase the pressure by turning the pressure control knob (ref# 75) clockwise to full pressure.
 4. Put pressure on the center of the exposed hydrapulse membrane with the handle of a screwdriver or other blunt object.
- NOTE:** The hydrapulse membrane is located between the paint head (ref# 21) and the hydraulic head (ref# 59)
5. If you are **UNABLE** to stop or alter the hydrapulse membrane's movement, then the hydraulic side is operating properly. The problem is located in the "Paint" pump. See troubleshooting guide for additional information.

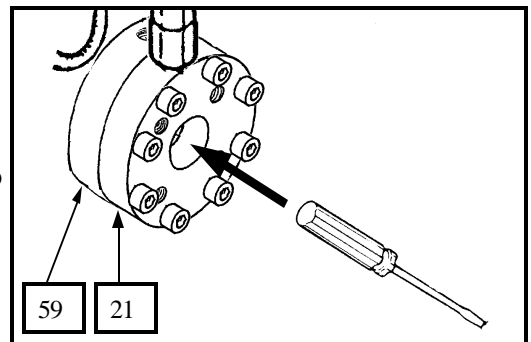
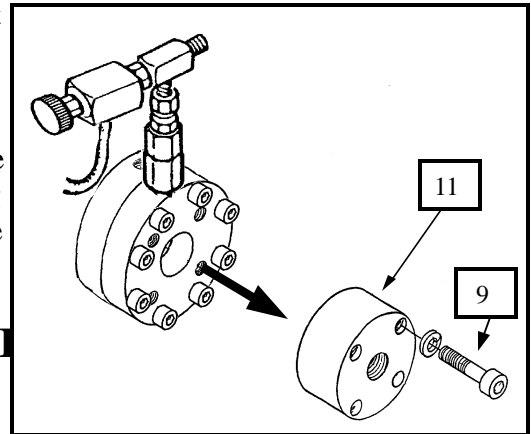

TROUBLESHOOT

SITUATION

POSSIBLE CAUSE (REMEDY)

GASOLINE ENGINE WON'T START/RUN

1. Pump under pressure. (reduce pressure setting by turning pressure control knob counter-clockwise, trigger gun to relieve pressure).
2. Fuel line valve closed. (open fuel line valve. See Honda

owners manual).

3. Engine switch in "OFF" position. (turn the engine switch to "ON" position).
4. Engine out of gasoline. (allow engine to cool, before adding appropriate levels of unleaded gas).
5. Engine is oil contaminated. Unit and engine must remain vertical or oil from the crankcase can enter the carburetor, air filter etc. (see an authorized Honda service center).

GASOLINE ENGINE STALLS/QUITS

1. See "GASOLINE ENGINE Won't Start/Run
2. Drive belt is loose. (tighten drive belts by evenly turning belt tension bolts on either side of engine clockwise. Check tension frequently. Loose belts generally emit loud squealing noises).
3. Unit primes, builds pressure, but pump "seizes" or "stops" when gun is triggered. (loose belts, tighten).
4. Engine requires tune-up. (see an authorized Honda service center).

TOTAL LOSS OF PRESSURE, HYDRAPULSE MEMBRANE MOVEMENT CANNOT BE STOPPED OR ALTERED. (SEE "HYDRAPULSE MEMBRANE TEST")

1. Paint too thick. (thin paint according to manufacturer's recommendations).
2. Intake ball (ref# 14) worn or jammed opened/closed. (remove intake endcap (ref# 11) and ball guide (ref# 17). Inspect intake ball,(ref# 14), to ensure it is free, round, and has no nicks or cuts. Inspect ball guide for excessive "bashing out" on the internal walls. Excessive wear causes the ball to become "lost" and unable to locate the seating surface. Inspect for foreign material jamming ball. Replace parts as needed).
3. Intake seat loose/bypassing. (remove intake endcap,(ref# 11) and ball guide, (ref# 17). Remove seat (ref# 13), inspect inlet washer (ref# 12) for excessive compression. Inspect for any sign of material bypass between intake seat and endcap cavity. **NOTE;** The proper alignment of intake parts, condition of intake washer (ref# 12), combined with the correct bolt torque are critical to the correct function of the intake valve. Replace the intake washer (ref# 12), each time the endcap is removed. See page 23 for more details.
4. Outgo valve ball (ref# 30) worn or jammed. (remove outgo valve,(ref# 26). Invert valve and unthread outgo valve upper,(ref# 31), from outgo lower,(ref# 27). Remove crush washer,(ref# 28), outgo seat, (ref# 29), outgo ball,(ref# 30), from outgo upper tunnel. Inspect outgo ball to ensure that it is round and free of nicks or cuts. Inspect for foreign material jamming ball. Inspect ball and cage for wear. Replace parts as needed).
5. Outgo valve (ref# 26) incorrectly assembled. (disassemble and reassemble outgo valve, closely following detailed instructions on page 26).

TROUBLESHOOTING

SITUATION

POSSIBLE CAUSE (REMEDY)

TOTAL LOSS OF PRESSURE, HYDRAPULSE MEMBRANE HAS NO MOVEMENT OR MOVEMENT CAN BE STOPPED. (SEE "HYDRAPULSE MEMBRANE TEST")

1. Hydraulic intake valve (ref# 66) defective. (remove hydraulic feed line, (ref# 67), from hydraulic intake valve. Plug hydraulic feed line so hydraulic fluid does not drain. Remove hydraulic intake valve

- from elbow, (ref# 62). Check hydraulic intake valve to ensure that it flows in one way only, into the cylinder. Replace if necessary. **NOTE;** Item cannot be repaired).
- Air lock created on hydraulic side of pump. (air entering hydraulic side due to loose hydraulic feed line fittings, (ref# 67), punctured hydraulic feed line, poor seal at hydraulic intake valve, (ref# 66), or elbow, (ref# 62). Tighten hydraulic feed line, test for leaks, or apply Teflon tape or pipe sealant on fittings. Purge air as per detailed instructions below).
 - Pressure control valve ball (ref# 88) worn out/jammed. (remove hydraulic return line, (ref# 73), from pressure control valve fitting, (ref# 82). Remove pressure control valve, (ref# 74), from elbow, (ref# 62). Disassemble pressure control valve, by removing valve seat, (ref# 87), from body, (ref# 83). Inspect for and remove foreign material. Inspect ball for wear. Install pressure control repair kit, (ref# 89), if necessary).
 - Piston rod (ref# 94) disconnected from piston (ref# 92). (reconnect piston rod following detailed instructions on page 24-25).

NO PRESSURE, BLUE HYDRAULIC FLUID IN PAINT

- Hydrapulse membrane broken. (replace with complete hydrapulse membrane, (ref# 54). Closely follow detailed instructions on page 21. **NOTE;** If, and only if, paint has contaminated the hydraulic side of the pump, the entire hydraulic system must be cleaned and flushed. Make sure to remove and clean the hydraulic tank screen,(ref# 70), during this process. Refill only with genuine H.E.R.O. LVO hydraulic fluid. **NOTE;** If lacquer has contaminated the hydraulic system, the piston seal, (ref# 91), must be changed in addition to flushing the system. Closely follow detailed instructions on page 24-25).

HYDRAULIC SIDE OF PUMP HAS BEEN REPAIRED AND REASSEMBLED, HYDRAPULSE MEMBRANE NOT MOVING "PURGING"

- Air lock created on hydraulic side of pump. (when the hydraulic side of the pump is working there is no air in it. During repairs it is possible that air has been trapped in the hydraulic system. It must be removed or the pump will not work. To purge the air from the hydraulic system; remove the pressure control knob, (ref# 75), from the valve. Gently pull the P.C. stem, (ref# 78), out. It will pull out about 1/8". Remove the vented hydraulic cap, (ref# 72), from the hydraulic tank, (ref# 69), and install accessory pressure cap, item 4-45-3. With a bicycle pump, apply a few pounds of air pressure to the hydraulic tank. This will force the oil through the hydraulic system and push out any of the trapped air. Wait a few minutes. Remove pressure cap and replace with vented cap. Restart the unit and install pressure control knob.

NOTE: Unit may be running during purging procedure to speed up the procedure. If a pressure cap is unavailable, simply running the equipment for approximately 5-10 minutes with the P.C. stem pulled out, will purge the system).

TROUBLESHOOTING

SITUATION

POSSIBLE CAUSE (REMEDY)

PUDDLE OF OIL APPEARING UNDER SPRAYER DURING OPERATION

- Hydraulic fitting loose/cracked or hydraulic lines are punctured. (examine all hydraulic lines and fittings for cracks, breaks or looseness. Replace or tighten as required).
- Piston seals (ref# 91) worn. (remove and replace piston seals, following closely the detailed instructions on page 24-25).

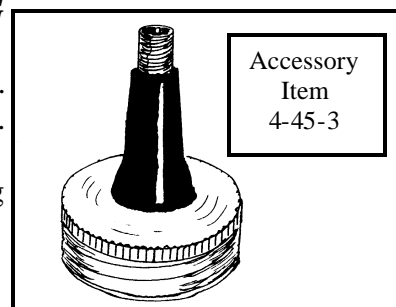

CORRECT STATIC PRESSURE, BUT REDUCED SPRAYING PRESSURE

(Check with pressure gauge, see page 16 for details).

1. Spray tip worn out/too large. (replace with new, correct sized spray tip. Tip must not exceed a newer condition .023 tip.)
2. Paint hose incorrect. (replace hose with genuine H.E.R.O. airless spray hose (min. 50 feet). Steel braided hoses must not be used).
3. Intake valve seat (ref# 13) worn. (replace intake seat closely following detailed instructions on page 23).
4. Intake ball (ref# 14) worn. (replace intake balls when signs of wear, deformation, nicks or cuts are evident. An out of round ball is the sign of a worn intake seat,(ref# 13), and both items should be replaced).
5. Outgo seat (ref# 29) worn. (replace seat).
6. Outgo ball (ref# 30) worn/damaged. (replace outgo ball).
7. Prime valve (ref# 36) bypassing. (start sprayer. With prime valve closed tightly, stem,(ref# 43), turned clockwise fully, check prime valve return hose, (ref# 51), for material bypass. Repair prime valve using, (ref# 40), if material is bypassing).

LOW STATIC PRESSURE, LOW SPRAY PRESSURE

(Check with pressure gauge, see page 16 for details).

1. Pressure control valve stem screw (ref# 80) loose. (remove pressure control knob,(ref# 75), and inspect screw for looseness. Screw should be secured to stem, (ref# 80), with Loc-Tite. If the screw turns independent of the stem than it must be re-secured. Secure unit so it will not move. Install pressure gauge and .021 spray tip. Obtain a piece of wood, to use as a pusher or purchase a pressure control adjustment tool, 27C-15. Remove pressure control screw and put some Loc-Tite 609 on threads. Turn the screw into the stem a few turns and push it in to its maximum and read pressure. Turn the screw in or out until 3000 psi static pressure is obtained. If you obtain a pressure which higher than 3000 psi, trigger gun to release some pressure and continue adjusting screw until correct pressure is obtained. Let Loc-Tite set up.
2. Pressure control ball (ref# 88) and/or seat (ref# 87) worn. (remove entire pressure control valve, (ref# 70), from sprayer. Remove valve seat, ball, retainer,(ref# 86), and spring,(ref# 85), from valve. Replace with pressure control repair kit,(ref# 89). Hold valve body vertical while placing in spring, followed by retainer. Retainer should be below the valve body (approx. 3/8") when positioned correctly. Center ball on retainer, turn valve seat into body until finger tight, using pipe dope or Teflon tape to seal. Fully tighten using wrench.

TROUBLESHOOTING

SITUATION

POSSIBLE CAUSE (REMEDY)

FLUID BEING SPRAYED OUT OF TIP PULSATES, SPRAY HOSE LIES QUIET WHEN GUN TRIGGER CLOSED

1. Spray tip worn out or too large. (replace with new tip of correct size. Tip must not exceed a single good condition .024 tip).
2. Paint hose incorrect type. (replace with genuine top quality H.E.R.O. airless spray hose. Steel braided hose is not recommended).
3. Too short a length of hose. (minimum 50' of airless spray hose is required. Replace or add hose until a

minimum of 50' is being used).

FLUID BEING SPRAYED OUT OF TIP PULSATES, SPRAY HOSE CONTINUES TO MOVE VIGOROUSLY WHEN GUN TRIGGER CLOSED

1. Outgo valve (ref# 26) assembled incorrectly. (remove the outgo valve and reassemble closely following the instructions on page 26).
2. Outgo valve ball (ref# 30) worn out or jammed. (inspect outgo ball to ensure that it is round and free of nicks or cuts. Inspect for foreign material jamming ball. Inspect seat and cage for wear. Replace parts as required).

PUMP SPRAYS WATER OR SOLVENT AT CORRECT PRESSURES, BUT WILL NOT SPRAY PAINT (Check with pressure gauge, see page 16)

1. Air leak in paint intake siphon assembly. (check all fittings and hose clamps in intake assembly for tightness).
2. Air leak in paint intake. (check for cracked or broken intake fittings. Swivel connector, (ref# 8), or hose barb,(ref# 7), may be damaged due to over tightening. Look for small black hairline fractures. Replace damaged parts).
3. Partial blockage in paint intake siphon hose, (ref# 5). (clean and remove any blockages from intake siphon hose. Check to insure strainer bag is not clogging intake siphon hose).

SPRAYER DOES NOT PRIME WITH PAINT

1. Heavy bodied paint, pump dry. (refer to " Operating Instructions" and follow priming instructions using the correct thinner for the paint you are to use).

SPRAYER DOES NOT PRIME WITH CORRECT THINNER

1. Pump completely dry.(pump may experience difficulty in priming when it is completely dry. First invert siphon tube and pour thinner into siphon tube, to help prime dry pump).
2. Intake siphon assembly (ref# 1) has loose/damaged fittings, loose clamps, or damaged hose.(check all fittings, hose clamps, for tightness, siphon hose for damage or holes. Replace or tighten as required).
3. Intake valve ball (ref# 14) stuck. (remove intake endcap,(ref# 11), and free ball and reassemble).
4. Outgo valve ball (ref# 30) stuck. (remove outgo valve,(ref# 26). Unthread outgo valve upper body, (ref# 31), from outgo body lower,(ref# 27). Remove outgo seat,(ref# 29), from upper body. Free ball and reassemble following detailed instructions on page 26).

TROUBLESHOOTING

SITUATION

POSSIBLE CAUSE (REMEDY)

SPRAY MATERIAL LEAKS AT PRIME VALVE STEM

1. Prime valve stem packings (ref# 41 or 42) defective. (replace damaged packings following detailed instructions on page 27).

SPRAY MATERIAL LEAKS OUT PRIME VALVE HOSE WITH VALVE CLOSED

1. Prime not closed tightly. (tighten valve stem,(ref# 43) further)
2. Prime valve worn. (install prime valve repair kit, (ref# 40). See page 27 for detailed instructions.)

SPRAY PATTERN IS SPOTTY OR UNEVEN

1. Pressure is too low. (increase pressure slowly until problem is corrected).
2. Spray material too thick. (thin as recommended by material manufacturer).
3. Plugged siphon screen, siphon tube, gun filter or a combination. (inspect and clean or replace as required).
4. Plugged tip. (remove and clean tip).
5. Pump malfunctioning or unsuitable for the material. (refer to other areas of troubleshooting guide and check material requirements vs 300GSD output abilities).

SPRAY PATTERN LEAVES LINES OR FINGERS

1. Pressure too low. (increase pressure slowly until problem is corrected).
2. Worn tip. (replace tip).
3. Tip too small for spray material. (change to larger tip or increase pressure. See material manufacturers recommendations).

EXCESSIVE OVERSPRAY OR FOGGING

1. Pressure too high. (reduce pressure as required).
2. Material too thin. (follow material manufacturers recommendations re-thinning).
3. Tip too large. (reduce tip size).
4. Improper application technique. (refer to proper application techniques on page 10-12).
5. Too windy. (wait for wind to let up).

HYDRAPULSE MEMBRANE REPLACEMENT (REF# 54)

TOOLS REQUIRED

- 1/4" Allen wrench
- 1/2" Open end wrench (2)

- 4-45-3 (accessory item)
- Torque wrench

Removal

1. Remove the eight bolts securing the material head (ref# 21) to the hydraulic head (ref# 59).
2. Remove the material head (22) and replace with the new provided.
3. Place a container under pump to oil.
4. Gently pull hydropulse membrane to separate it from the head.
5. Remove the nut (ref# 58) on the membrane stem in order to separate membrane from the hydraulic (ref# 55), hydropulse membrane (56), and spring locator (ref# 57).
6. Clean all parts.

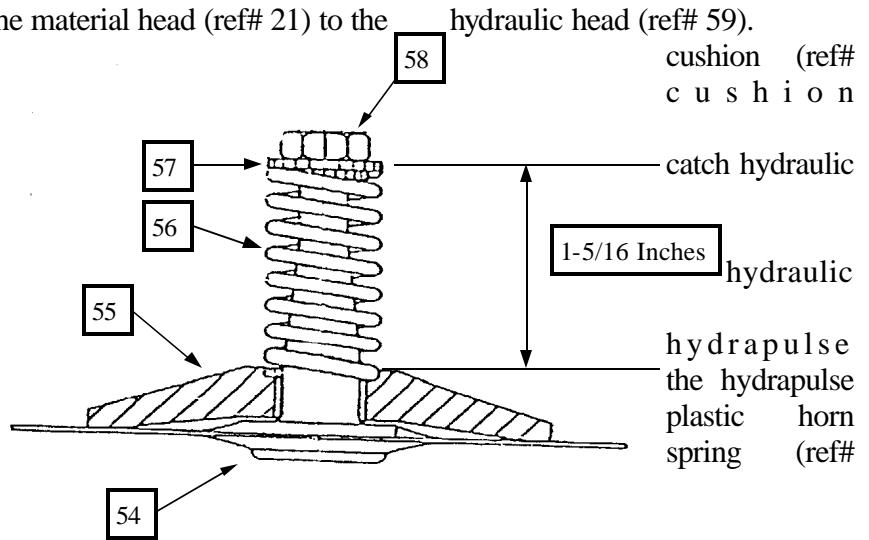

Assembly

1. Place hydraulic plastic horn over the new hydropulse membrane.
2. Position the spring in the bore of the plastic horn.
3. Install the spring locator over the hydropulse membrane stem and into the spring. Thread the jam nut onto the stem.
4. Tighten the jam nut until a measurement of 1-5/16" is obtained. The measurement is taken from the top of the hydraulic horn (ref# 55) to the top of the spring locator (ref# 57). See diagram above.
5. Check the assembly. The spring must be positioned in the bore of the plastic horn on one end and over the shoulder of the spring locator on the other end.
6. Place the hydropulse membrane assembly back into the hydraulic head.
7. Re-install the material head with the eight bolts. Torque to 30 ft. lbs.
8. Refill hydraulic oil tank and "PURGE" system following instructions on page 18.
9. Prime the pump with solvent or water and bring the pump up to full pressure (approximately 2500 psi.). Run the pump on standby (not triggering gun) for about 20 minutes, to "break-in" new membrane.
10. Installation is now complete and the pump is ready for use.

REPLACEMENT OF INTAKE SEAT (REF # 13)

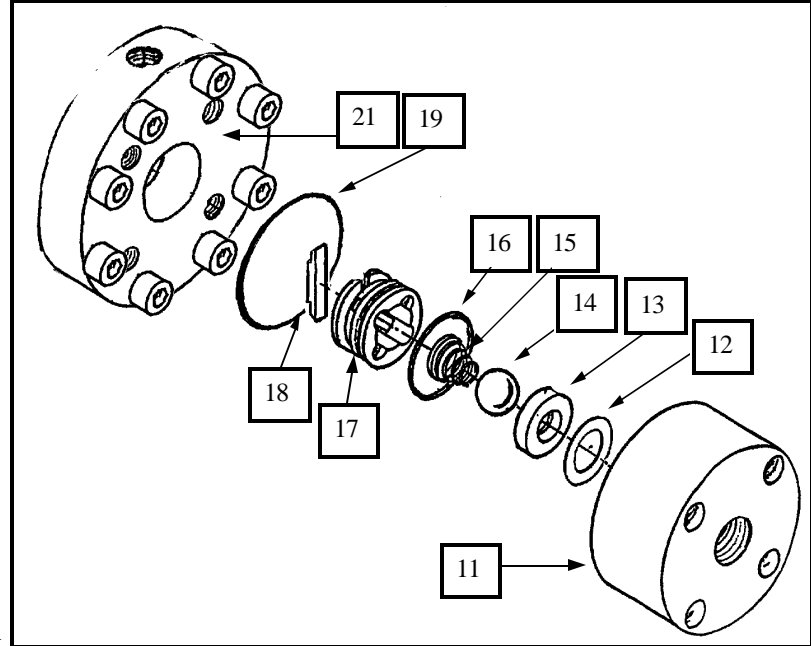
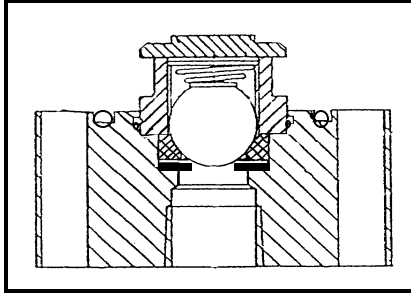

TOOLS REQUIRED

- 5/16" Allen wrench
- vise
- torque wrench
- screwdriver

1. Remove the four bolts (ref# 9) and pull intake endcap (ref# 11), from the pump. The endcap should separate from the material head (ref# 21), with the ball guide (ref# 17) attached. If the ball guide remains in the material head, pry out with a screw driver.
2. Clamp endcap in vise with the ball guide facing up.
3. Pry off the ball guide and remove intake ball (ref# 14) and spring (ref# 15).
4. Remove seat from endcap. **NOTE; The seat is not secured with any Loc-Tite, however dried paint may cause difficulty in removing seat.**
5. Remove the crush washer (ref# 12).
6. Thoroughly clean and inspect all parts. Replace any worn or damaged parts.
7. Place clean endcap in vise with o-ring (ref# 19) groove facing up.
8. Assembly of parts is the reverse of removal; washer (ref# 12), seat (ref# 13), and ball (ref# 14). **NOTE; A new compression washer should be used each time the endcap is removed**
9. If the ball guide (ref# 17) and ball stop (ref# 18) were separated during removal, re-assemble the two. **NOTE; The step on the ball stop must face outwards (Towards hydrapulse membrane).**
10. Place the spring (ref# 15) into the ball guide so the smaller end of the spring will contact the ball.
11. Assemble the ball guide, with spring, onto the endcap over the already installed ball and seat. Push down on the ball guide so that the ball guide o-ring (ref# 16) locks the assembly together.
12. Place o-ring (ref# 19) in the groove on the face of the endcap.
13. Install the entire endcap assembly onto the material head with the four bolts (ref# 9). Torque bolts, using a crisscross pattern, to 20 ft. lbs. Repeat torquing procedure using 30 ft. lbs.

NOTE: Effective March 1997, and beginning with serial number 310313, a new style Hydrapulse "Intake" assembly is used. The changes effect the Endcap (ref# 11), Crush Washer (ref # 12), Ball Guide (ref# 17), Ball Stop (ref# 18), and the Material Head (ref# 21). The most significant change is to the endcap. Gone is the o-ring, formerly located under the intake seat. The endcap is machined flush and a new crush washer is now placed in before the seat (crush washer is placed under the seat). The seat will be held in place through the compression of parts during assembly.

PISTON REPAIRS

(REF# 90)

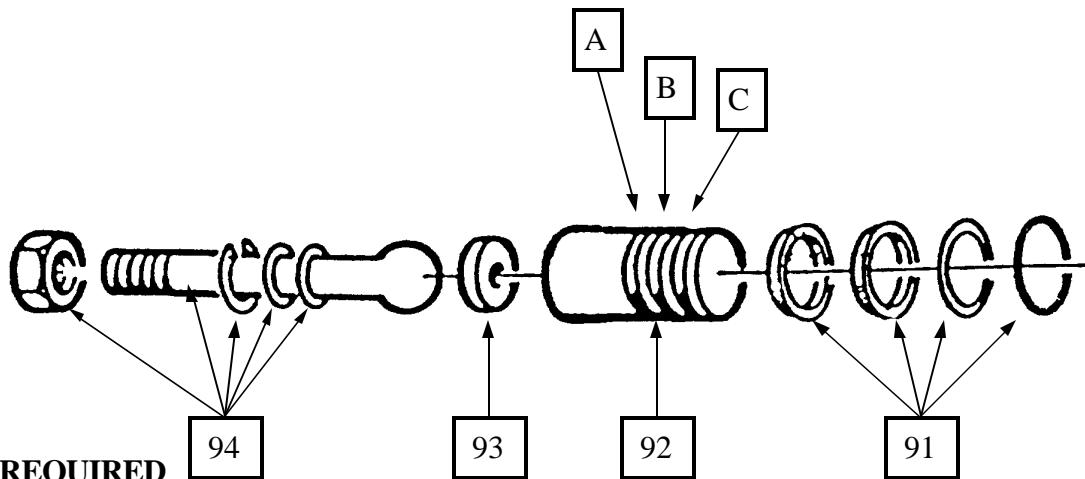

TOOLS REQUIRED

- 1/2" wrench
- 11/16" wrench
- circlip pliers
- torque wrench
- grease
- vise grips

1. Remove hydraulic feed line, (ref# 67) from hydraulic intake valve, (ref# 66) and also remove hydraulic return line, (ref# 73) from the pressure control valve, (ref# 74). Plug lines to minimize oil loss. (Hint; golf tees work well for this)
2. Remove the bolts, (ref# 117) passing through the side frames, (ref# 115,116), into the crossblock, (ref# 63).
3. Place a drain tray under cylinder area.
4. Grasp the pump assembly, and pull away from the piston. Stop when piston pulls free, to allow the hydraulic oil to drain into pan. Completely remove pump assembly from between side frames.
5. If only replacing piston seals, (ref# 91) continue at step 15.
6. Remove the piston, (ref# 90) from eccentric bearing, (ref# 100). Move to clean work bench for repairs.
7. Remove piston circlip, using circlip pliers. Remove piston from rod.
NOTE: Use extreme caution not to damage circlip or the internal circlip groove of piston.
NOTE: Piston rod circlip, washer, o-ring, and nut are not available individually. Parts are available with the purchase of piston rod, (ref# 94) only.
NOTE: The circlip will have one sharp edge and one smooth edge. The smooth edge should be towards the washer. If reversed, the rod will continually pull out of the piston.
8. Remove bronze piston rod seat, (ref# 93) from piston, (ref# 92).
9. Examine all parts for wear or damage. Replace as required.
10. Fill the center cavity of piston rod seat until flush with grease. Slide seat into piston with concave side (filled with grease) facing out.
11. Lightly grease the ball end of piston rod. Push piston rod into piston until ball end of rod contacts seat.

PISTON REPAIRS

12. Slide o-ring and steel washer down rod and into piston. Slide circlip down into piston and snap into the

internal circlip groove of piston using circlip pliers.

NOTE: Circlip must fully expand into groove of piston. Circlip has fully expanded when there is 13/64" space between circlip eyelets.

NOTE: If you experience difficulty installing circlip, remove a small quantity of grease. When installed correctly, rod should move slowly and without any free play.

13. If piston seals, (ref# 91) are required, they may be installed now or after piston has been re-attached.
14. Thread rod into eccentric bearing holder, (ref# 102) until nut is flush with eccentric bearing. Tighten snugly.
NOTE: Piston rod nut must remain fully threaded onto rod, if during installation, the nut begins to loosen from rod, re-tighten to rod. Place vise grips on rod to assist in tightening piston rod into eccentric.
15. Remove and discard old piston seals.
16. Piston seal kits, (ref# 91) contain a total of four pieces (1 o-ring, 1 flat washer, 2 cup washers). Take note of their installation sequence by referring to drawing. The piston has three machined grooves, which have been marked on the drawing as A, B, & C.
17. Place flat washer (one side has a contoured face) into groove "C", then place o-ring in front of flat washer, so that it fits into the contoured face of the flat washer.
18. Place one cup washer into groove "B", with open face of cup washer facing the end of piston. (towards hydraulic oil when installed)
19. Place second cup washer into groove "A".
NOTE: Always work from the front of the piston back so that you are always moving the cup washers over filled grooves. This avoids damage that can occur to the cup washers if they have to be dug out of one groove and moved to another. Avoid over stretching.
NOTE: A small, dental like tool, may be used to assist in moving cup washers.
20. Apply grease to seals before installing in cylinder, (ref# 61).
21. Slide pump assembly into side frames and guide piston into cylinder.
NOTE: Use care not to push the piston too far into cylinder. If piston rings slide in too far they will pass through cylinder into the hydraulic cavity. Complete dismantling of piston will be required to remove. The piston can not be pulled back if the seals have gone through cylinder.
22. Reattach crossblock bolts, as removed in step 2. Torque bolts to 30 foot pounds.
23. Reconnect hydraulic lines, as removed in step 1.
24. Add new hydraulic oil to hydraulic tank, using only genuine H.E.R.O. LVO hydraulic oil.
25. Once the repairs have been completed, the hydraulic oil will require purging to remove the trapped air. See "**PURGING**" instructions on page 18.

OUTGO VALVE (REF# 26)

TOOLS REQUIRED:

- 1" wrench
- vise
- Teflon tape

1. Open prime valve, (ref# 36) in order to release pressure from the material side of pump.
2. Remove pressure control knob, (ref# 75) and pull P.C. stem, (ref# 78) out to internal stop, thereby releasing hydraulic pressure.
3. Disconnect outgo tee, (ref# 35) from outgo swivel, (ref# 32) on the outgo valve.
4. Remove outgo valve from machine by turning counter clockwise.
5. Invert valve and secure upper part of valve, (ref# 31) in vise.
6. Remove lower half of valve, (ref# 27).
7. Remove crush washer, (ref# 28), seat, (ref# 29), and ball, (ref# 30). Clean and inspect all parts for wear. Replace any worn parts.

Outgo swivel
ref# 32
Not Shown

NOTE: Check the condition of the internal passage ways of the outgo upper (ref# 31). A total of five holes allow the paint to pass through the upper. The center hole will become enlarged over time and cause the ball to travel a greater distance than originally intended. This can cause a reduction in the response time of the valve and lead to pulsation in the spray hose and spray pattern.

8. Apply Teflon tape to threads of outgo upper body.
9. Invert outgo upper and drop ball in.
10. Install seat, beveled side down to ball. Seat should fit snugly into outgo body. Press on seat to ensure it will compress until it is flush with outgo body.
11. Place crush washer on seat. Replace crush washer if badly crushed.
12. Thread outgo lower onto outgo upper until finger tight. Tighten 1/2 turn with wrench. **NOTE:** Teflon tape or pipe sealant should be used.
13. Attach repaired valve to machine, installing a new crush washer, (ref# 25) following steps 3-4 in reverse order.

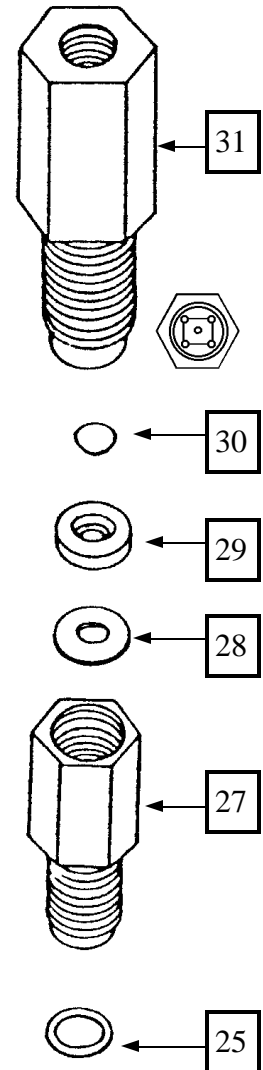
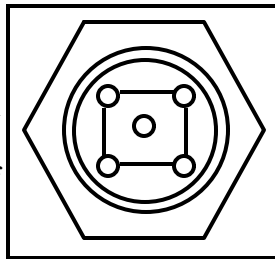

SPECIAL NOTES:

- * To check the ball for wear, place against a new seat and check sealing edge against a bright light.
- * A used seat may be checked in a similar manner using a new ball. Replace used part if light pass at sealing edge.

**PRIME VALVE REPAIRS
(REF# 36)**

Tools or Supplies Required

- ◆ Vise
- ◆ 9/16 Open end wrench
- ◆ 3/4 Open end wrench
- ◆ 5/8 Open end wrench
- ◆ Teflon Tape or pipe sealant, optional *
- ◆ Loctite, optional **

Bleed Valve Repair Kit Installation

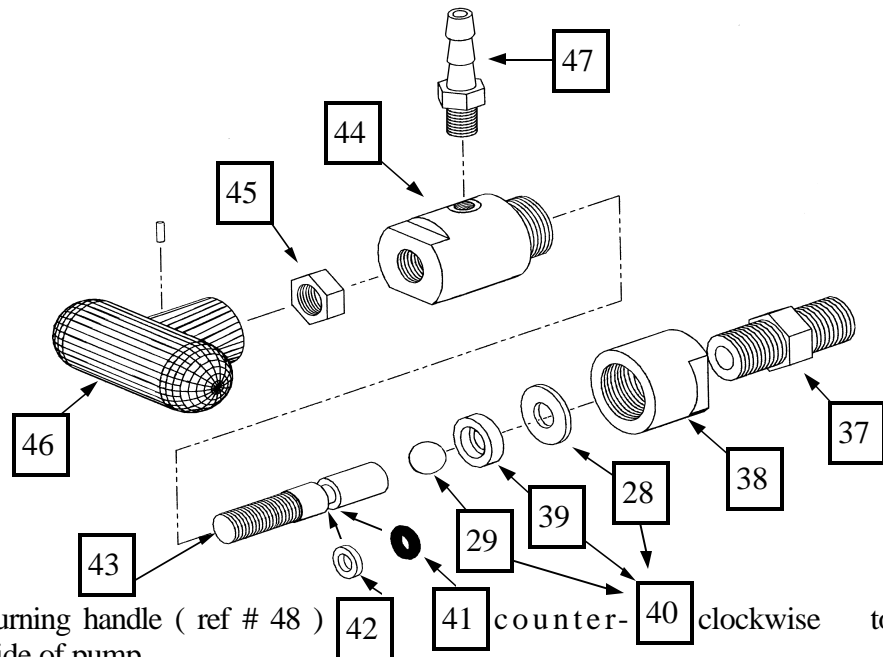

1. Open bleed valve (ref # 38), turning handle (ref # 48) counter-clockwise to release pressure from material side of pump.
2. Remove bleed valve return hose, (ref # 51) from bleed valve return fitting, (ref # 49).
3. Place wrench on bleed valve connector, (ref # 39). Turn counter-clockwise to remove valve from outgoing tee, (ref # 37).
4. Secure valve vertically in vise, clamping vise jaws on the flats of valve nut (ref # 40).
5. Use wrench to remove valve housing (ref # 46) from nut, (ref # 40).
6. Remove ball, (ref # 41), seat, (ref # 29) and crush washer, (ref # 28).
7. Install new crush washer and seat, (ensuring the beveled surface of seat is facing out) into the bleed valve nut (ref # 40). Place new ball into bevel of seat.
8. Re-install valve housing (* Use of Teflon Tape or pipe sealant is optional). Tighten 1/4 turn past finger tight. If leakage occurs at this junction point during operation, tighten 1/4 turn more or until leakage stops.

To install new valve stem, or valve stem seals, (ref # 44 or 43), continue at step 9 .

9. Complete steps 1 to 5 from above.
10. Place valve housing in vise.
11. Use 1/2" wrench to loosen jam nut (ref # 47), and remove handle.
12. Remove jam nut from valve stem (ref # 45), and unthread valve stem down through housing.
13. Remove existing o-ring and washer (ref # 44 & 43) from stem. Replace with new parts, ensuring they are installed in the correct order on stem. Refer to diagram.
14. Thread stem back into housing until all threads are used. Thread jam nut on to valve stem.
15. Re-assembly valve. Refer to steps 6 to 8 from instructions above.
16. Thread handle onto valve stem. Allow stem to thread down onto ball (internally). Tighten handle firmly.
17. Hold handle while tightening jam nut (Ref # 47) tightly against handle. (** Use of Loctite is optional **)

PRESSURE CONTROL VALVE (REF# 74)

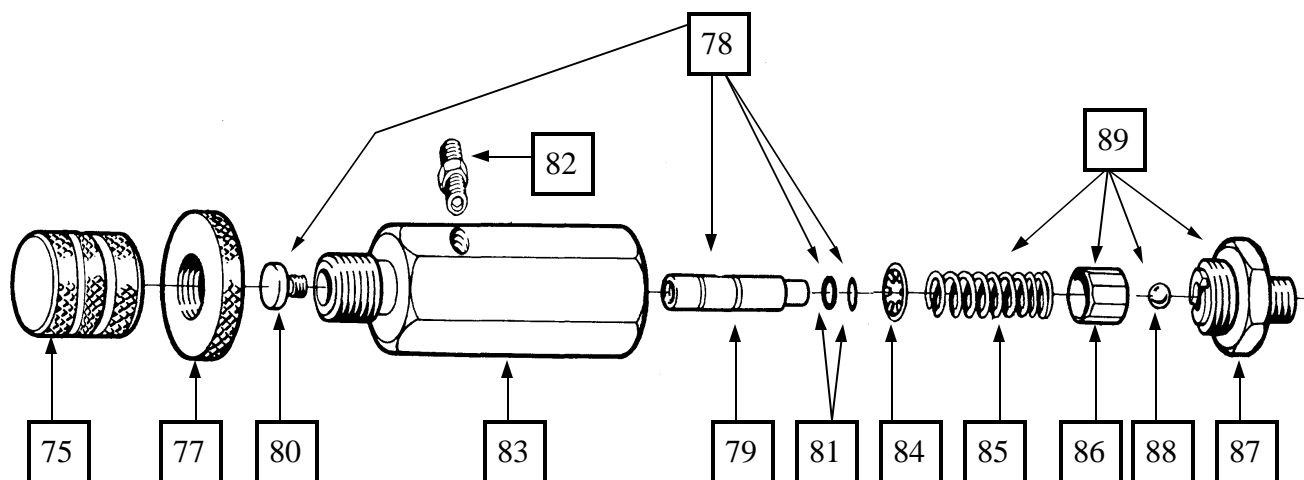

TOOLS REQUIRED

- 1" wrench
- 11/16" wrench

1. Remove pressure control knob, (ref# 75) and pull P.C. stem, (ref# 78) out to the internal stop (1/16" to 1/8") thereby releasing hydraulic pressure.
2. Remove hydraulic return line, (ref# 73) from P.C. fitting, (ref# 82).
3. Place 11/16" wrench on P.C. seat, (ref# 87). Turn counter-clockwise to remove complete valve.
4. Place complete valve in vise and remove seat from body, (ref# 83).
5. Remove ball, (ref# 88), retainer, (ref# 86), and spring, (ref# 85) from body. Inspect ball for nicks or cuts and replace if damaged. Inspect seat at sealing edge, for signs of wear. A good condition seat will have a very small beveled at the sealing edge. The larger the bevel the more wear has taken place. Inspect retainer for wear. The retainer has a small locating hole in it. The hole should be flush or slightly beveled. The greater the wear on the ball, seat, and retainer the poorer the static pressure will be. Replace parts individually, or use repair kit, (ref# 89).
6. Hold P.C. body vertical. Place spring into body, place retainer onto spring. Ensure retainer fits completely over spring. Retainer should rest below end of body by approximately 1/4" to 3/8". Place ball onto retainer, ensuring ball is located on center hole.
7. Thread on seat, using care not to dislodge the ball from its position on the retainer. Tighten firmly.
8. Apply pipe dope or Teflon tape to exterior threads of seat. Install into elbow. Tighten to prevent leaks and return to original position.
9. Reattach hydraulic line.
10. See "**PURGING**" instructions on page 18.

ACCESSORY PARTS LIST

H.E.R.O. Accessories

114	Hose, Airless Paint, 50' x 1/4"	4-649	Wonder Wash, Case, 48 x 1.5 oz.
117	Hose, Airless Paint, 50' x 3/8"	4-650	Wonder Wash, single, 5 oz
3-Whipend	Whipend, 3' x 3/16"	4-655	Wonder Wash, Case, 25 x 5 oz
1/4 x 1/4	Connector, to join 2 hose (1/4")	4-660	Wonder Wash, Bulk, 5 lbs.
4-67/19	Pressure Gauge, c/w Tee, 3000 PSI	4-662	Wonder Coat, 1 liter
4-45-3	Pressure Cap, Hydraulic tank	4-664	Wonder Coat, Case, 12 x 1 liter
67/18B	Hex Key Set	4-666	Wonder Coat, Case, 4 liter
5 GAL S.B.	Strainer Bag, 5 Gallon	4-668	Wonder Coat, Case, 4 x 4 liter
5 GAL PL	Plastic Liner, 5 Gallon	661	Spray Trigger
4-LVO-1	Hydraulic Oil, 1 liter	620-HTO	Video, How To Operate
4-LVO-4	Hydraulic Oil, 4 liter	620-HTP	Video, How To Paint

ASM Accessories

10-55-2406	6" Mini Pole	10-55-7302	2' Maxi Pole
10-55-2412	12" Mini Pole	10-55-7303	3' Maxi Pole
10-55-2418	18" Mini Pole	10-55-7306	6' Maxi Pole
10-55-2424	24" Mini Pole	10-55-7309	9' Maxi Pole
10-55-013-2	300 Gun, 1710 Flip, 2 Finger	10-55-013-4	300 Gun, 1710 Flip, 4 Finger
10-55-011-2	400 Gun, 1710 Flip, 2 Finger	10-55-011-4	400 Gun, 1710 Flip, 4 Finger
10-55-PRO5-2	PRO5 Gun, 1710 Flip, 2 Finger	10-55-PRO5-4	PRO5 Gun, 1710 Flip, 4 Finger
10-55-4433	50 Mesh, Gun Filter, White	10-55-4435	200 Mesh, Gun Filter, Red
10-55-4434	100 Mesh, Gun Filter, Yellow	10-55-4436	30 Mesh, Gun Filter, Green
10-55-5701F	Hand Tight Base, 11/16"-16	10-55-5701G	Hand Tight Base, 7/8"-16
10-55-5501F	Wrench Tight Base, 11/16"-16	10-55-5501G	Wrench Tight Base, 7/8"-16
10-55-5502	Seal Kit, for 5501F or 5501G	10-55-5702	Seal Kit, for 5701F or 5701G

Flip Tips (all prefixed by; 10-55-)

0904	1104	1304	1504	1704	1904	2104	
0906	1106	1306	1506	1706	1906	2106	
	1108	1308	1508	1708	1908	2108	
	1110	1310	1510	1710	1910	2110	2310
		1312	1512	1712	1912	2112	2312

PARTS LIST

Please order parts by the appropriate part number and not by reference number.
The quantity required, per unit, is shown for each part number. Part numbers in **bold** text indicate whole assemblies or kits. These parts may also be purchased individually

INTAKE PARTS

REF	PART #	DESCRIPTION	QTY
1	4-210	SIPHON ASSEMBLY COMPLETE, (Ref# 2-7, 51-53)	ASSY
2	187A	SCREEN, Siphon, Coarse, Includes	1
3		NOT USED	
4	189A-1	TUBE, Siphon, Metal, 5 Gal.	1
5	4-184A	HOSE, Siphon, 21"L x 3/4" ID, Lacquer Resistant	1
6	1/75-3	CLAMP	2
7	667-27	BARB, Hose to Elbow, 3/4"	1
8	667-26	ELBOW, 3/4"	1
9	HW1087	CAPSCREW, SKT HD, 3/8 NC x 2", Gr. 8	4
10	3-2	WASHER, 3/8" Hi Collar Lock	4
11	4-02-22-2502B	ENDCAP, Hydrapulse, Gold <i>NEW, after serial # 310313</i>	1
12	02-22-2009B	WASHER, Crush <i>NEW, after serial # 310313</i>	1
13	6	SEAT, 3/4" Tungsten Carbide	1
14	17S	BALL, 3/4", Corrosion Resistant	1
15	02-22-2005	SPRING	1
16	02-22-2006	O-RING, Urethane	1
17	02-22-2002B	BALL GUIDE <i>NEW, after serial # 310313</i>	1
18	02-22-2001B	BALL STOP <i>NEW, after serial # 310313</i>	1
19	5V	O-RING, Viton	1
20	3	CAPSCREW, SKT HD, 5/16 x 1-3/4"	8
21	4-02-22-2501B	HEAD, Material, Hydrapulse, Gold <i>NEW, after serial #</i>	1
22	02-22-2004	CUSHION, Material Head	1
23	4-6658B	REPAIR KIT (Ref# 12, 14-15, 19) <i>NEW, after serial # 310313</i>	KIT
24	4-6659B	OVERHAUL KIT (Ref# 12-19) <i>NEW, after serial # 310313</i>	KIT

OUTGO PARTS

25	7C	WASHER, Copper Crush	1
26	4-611C	OUTGO VALVE COMPLETE, (Ref# 27-32)	ASSY
27	11A-1	LOWER, Valve Body	1
28	11A-3CP	WASHER, Copper Crush	1
29	11A-45	SEAT, 3/8, Tungsten Carbide	1
30	11A-5S	BALL, STEEL, 3/8	1
31	11B-2	UPPER, Valve Body, for use with steel ball	1

PARTS LIST

Please order parts by the appropriate part number and not by reference number.
The quantity required, per unit, is shown for each part number. Part numbers in **bold** text indicate whole assemblies or kits. These parts may also be purchased individually

OUTGO PARTS

REF	PART #	DESCRIPTION	QTY
32	20	SWIVEL	1
33	4-6656	REPAIR KIT (Ref# 25, 28, 30)	KIT
34	4-6657	OVERHAUL KIT (Ref# 25, 28-30)	KIT
35	13-1	TEE, Female x Male x Male	1
36	4-606	BLEED VALVE COMPLETE (Ref# 37-47)	ASSY
37	14A	CONNECTOR, 1/4 x 1/4	1
38	606-2	NUT, Bleed Valve	1
39	11A-4	SEAT, Tungsten Carbide	1
40	4-606RK	REPAIR KIT, Bleed Valve (Ref# 28, 29, 39)	KIT
41	606-8	O-RING, Bleed Valve Stem	1
42	606-15	WASHER, Back-Up, B.V.	1
43	606-10	STEM, B.V.	1
44	606-1	HOUSING, B.V.	1
45	HW4053	NUT, Hex Jam	1
46	4-606-9	HANDLE, "T", Complete with pin	1
47	603-6	BARB	1
48	603-12	LABEL, "Close Tightly After Prime"	1
49	606-12	LABEL, Bleed Valve, "Max WPR 4000 PSI"	1
50	** NOT	** NOT USED **	**
51	4-185B	HOSE, P.V. Return Line	1
52	196	CLAMP	1
53	188	TIES	2

HYDRAULIC PARTS

54	4-04-22-4500	HYDRAPULSE MEMBRANE (Includes Ref# 22 & 58)	KIT
55	04-22-4001	HORN, Plastic	1
56	04-22-4005	SPRING	1
57	04-22-4004	LOCATOR	1
58	HW4032	NUT, 5/15NC Hex Ny-Lock	1
59	4-04-22-4501	HEAD, Hydrapulse, Gold	1
60	5	O-RING	1
61	24/75	CYLINDER, 3/4",	1
62	25-2	ELBOW	3

PARTS LIST

Please order parts by the appropriate part number and not by reference number.
The quantity required, per unit, is shown for each part number. Part numbers in **bold** text indicate whole assemblies or kits. These parts may also be purchased individually

HYDRAULIC PARTS

REF	PART #	DESCRIPTION	QTY
63	35A	CROSSBLOCK, Aluminum	1
64	36	CAPSCREW, HX. HD., 5/16NC x 3", Gr. 5	6
65	HW5050P	WASHER, 5/16" SAE	6
66	4-30	VACUUM VALVE	1
67	4-31	FEED LINE, LVO, C/W Fittings, Includes ref# 68	1
68	31-1	ORIFICE, Metering	1
69	4-45A	TANK, Complete With Fittings, (ref# 70-72)	ASSY
70	4-45-1	SCREEN, Tank	1
71	45-4	ELBOW, Return	1
72	4-45-2	LID, Vented, Hydraulic Tank	1
73	4-28	RETURN LINE, LVO, C/W Fittings	1
74	4-27C	PRESSURE CONTROL VALVE, Complete (Ref# 75-88)	ASSY
75	4-27C-7	KNOB, P.C., Includes Ref# 76	ASSY
76	HW2010	SETSCREW, SKT. HD. 5/16 NC x 5/16"	1
77	27C-6	LOCK NUT, Aluminum, P.C.	1
78	4-27C-10	STEM ASSEMBLY (Ref# 79-81)	ASSY
79	27C-10A	STEM, P.C.	1
80	27C-10B	SCREW, Stem, P.C.	1
81	27C-12	O-RING, P.C.	2
82	4-27C-11	FITTING, Oil Return, P.C.	1
83	27C-8	BODY, P.C.	1
84	27C-9	CIRCLIP, P.C.	1
85	27C-5	SPRING, P.C.	1
86	27C-4	RETAINER, P.C.	1
87	27C-3	SEAT, 38-40RC, P.C.	1
88	27C-2	BALL, Steel	1
89	4-27CRK	REPAIR KIT, Ref# 85-88	KIT
90	4-38A/75	PISTON & ROD ASSEMBLY, 3/4" (Ref# 91-94)	ASSY
91	4-37A/75	SEAL SET, Piston, 3/4"	1
92	4-38A/75-1	PISTON, Only, W/O Seals, 3/4"	1
93	38A-3	SEAT, Piston, Bronze	1
94	4-38A-2	ROD, Piston, C/W Nut, Washer, O-Ring, Circlip **Nut, Washer, O-Ring & Circlip NOT Sold Individually**	1

PARTS LIST

Please order parts by the appropriate part number and not by reference number.
The quantity required, per unit, is shown for each part number. Part numbers in **bold** text indicate whole assemblies or kits. These parts may also be purchased individually

DRIVE PARTS

REF	PART #	DESCRIPTION	QTY
95	42	BEARING, Crankshaft Side	2
96	HW1090P	CAPSCREW, HX HD, 7/16NC x 1 1/4	4
97	HW5070P	WASHER, Lock, 7/16	4
98	HW4060P	NUT, HX. HD, 7/16	4
99	40	COUNTERWEIGHT, Plain Bolt Hole	1
100	4-39	ECCENTRIC BEARING & HOLDER, (Ref# 101,102)	ASSY
101	39-2	BEARING, Eccentric, Outer	1
102	4-39-3	Holder, Eccentric, C/W Zerk	1
103	4-41	CRANKSHAFT, Includes Ref# 99	ASSY
104	39-1	RACE, Eccentric, Inner	1
105	44	COUNTERWEIGHT, Tapped Bolt Hole	1
106	43	BOLT, SKT HD, 1/4NC x 2	1
107	4-49	KEYSTOCK, 3/16 SQ x 1.5"	2
108	4-65/100	SHEAVE, Pump, C/W Set Screws (2) (Includes ref# 109)	1
109	HW2020	SET SCREW, SKT. HD., 5/16 NC x 7/16	2
110	66/100	BELT	2
111	4-48/103	SHEAVE, Motor, C/W Set Screws (2) (Includes ref# 109)	1
112	4-62/103	ENGINE, Honda, 2.5 HP	1
113	HW1072P	CAPSCREW, HX HD, 5/16NC x 1 1/4"	4
114	HW5050P	WASHER, Flat, 5/16	4

CHASSIS PARTS

115	4-53	FRAME, Left Side	1
116	4-52	FRAME, Right Side	1
117	HW1060P	CAPSCREW, HX HD, 5/16NC x 3/4	6
118	HW5051P	WASHER, Flat, 5/16	6
119	45B	BRACKET, For Hydraulic Tank	1
120	45C	STRAP, For Hydraulic Tank	2
121	45D	PAD, Rubber	1
122	HW1010P	CAPSCREW, HX HD, 1/4NC x 1/2"	2
123	4-61	BRACKET, Motor Mount (Includes ref# 124, 125)	1
124	HW1200F	CAPSCREW, HX HD, 3/8" x 1 3/4"	2

PARTS LIST

Please order parts by the appropriate part number and not by reference number.
The quantity required, per unit, is shown for each part number. Part numbers in **bold** text indicate whole assemblies or kits. These parts may also be purchased individually

CHASSIS PARTS

REF	PART #	DESCRIPTION	QTY
125	HW4053	NUT, Hex Jam, 3/8NC	2
126	4-67/13B	FRONT LEG	1
127	HW1020P	CAPSCREW, HX HD, 1/4NC x 3/4	10
128	HW5030P	WASHER, Flat, 1/4	10
129	4-67/23	FOOT PAD	2
130	HW1030	CAPSCREW, HX HD, 1/4NC x 1 1/4	2
131	HW5034P	WASHER, Fender, 1/4 x 1-1/4	2
132	HW5040P	LOCK, Washer, 1/4	12
133	HW4020P	NUT, 1/4	12
134	4-1/75-13	HANDLE, Front	1
135	198	AXLE	1
136	2/78	HANDLE, Snap On, Rear	1
137	67/16A	WHEEL, Pneumatic	2
138	67/17	COTTER PIN	2
139	4-66/14	BELTGUARD	1

DECALS

140	97B	“Quality By Design” 300GSD	1
141	92	“ Release Pressure ”, Belt Guard	1
142	91	“H.E.R.O.” Small, Engine	1

PARTS SCHEMATIC

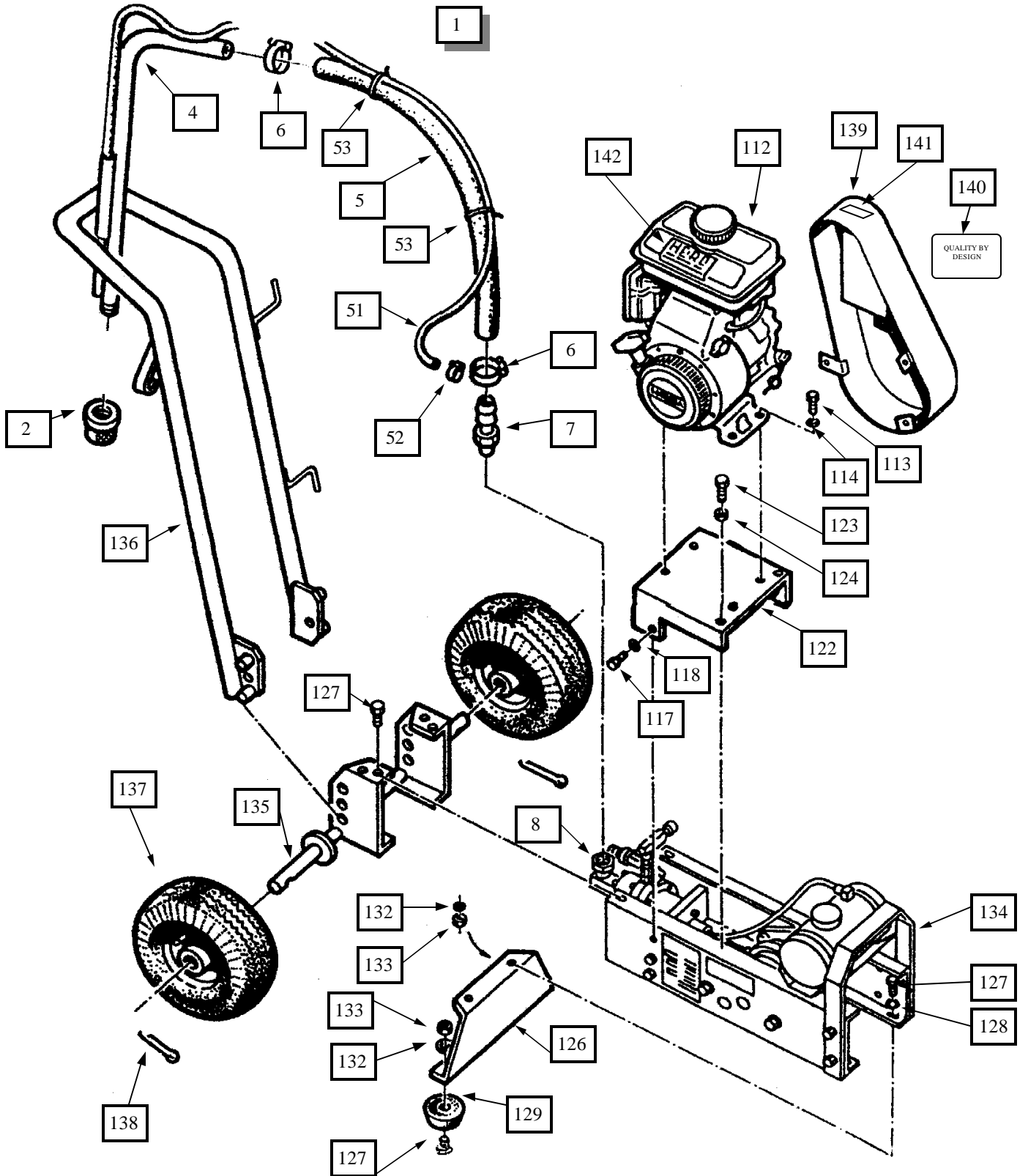

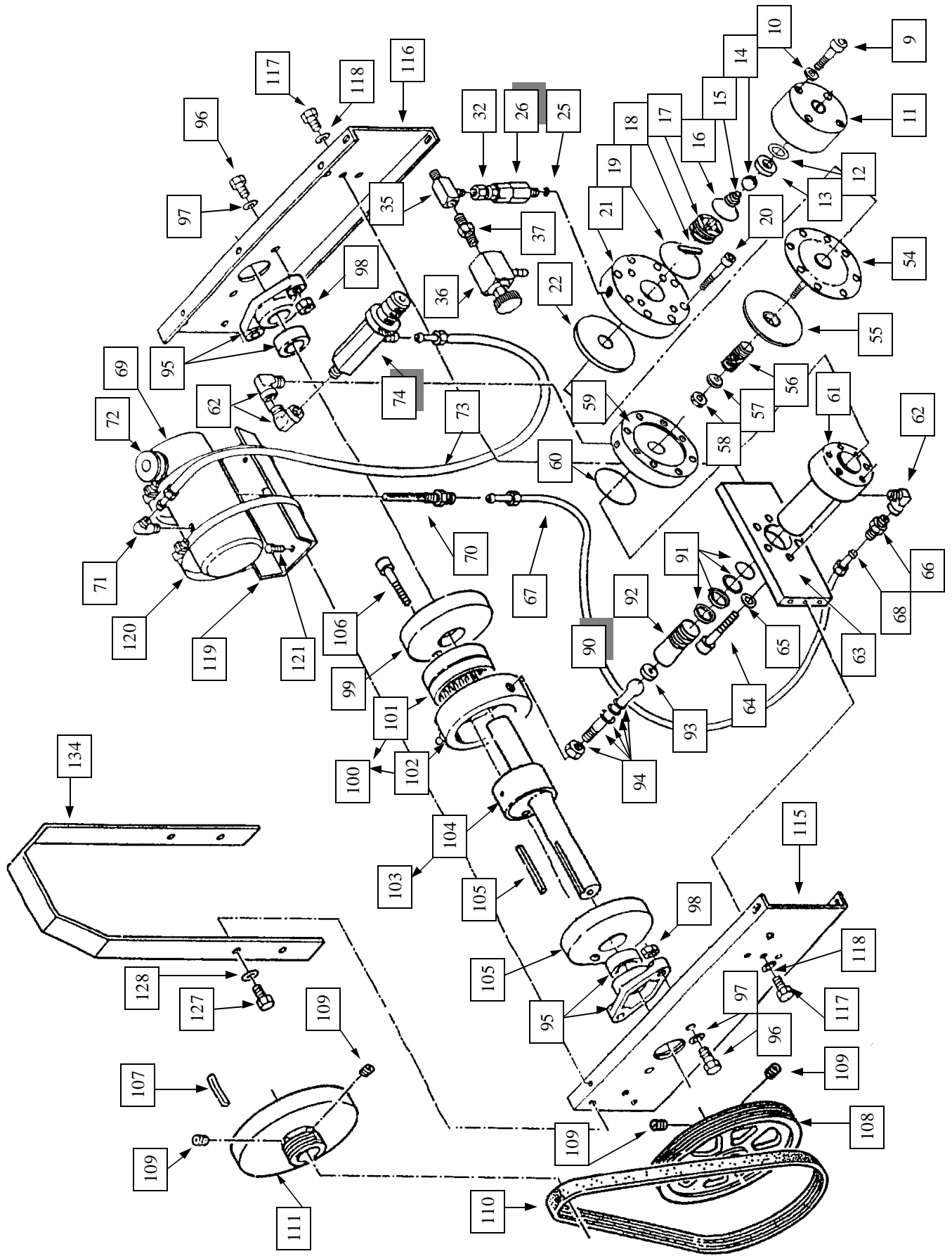

300GS-D

MANUFACTURED BY:
H.E.R.O. INDUSTRIES
2719 LAKE CITY WAY
BURNABY, B.C.
CANADA

PHONE: 604-420-6543
800-494-4376
FAX: 604-420-8725

PURCHASED FROM

MODEL: _____

SERIAL #: _____

DATE OF PURCHASE:
